

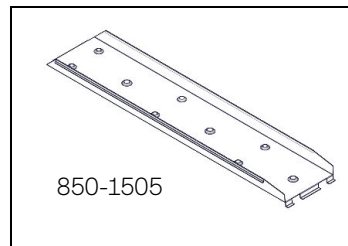

Residential

Commercial

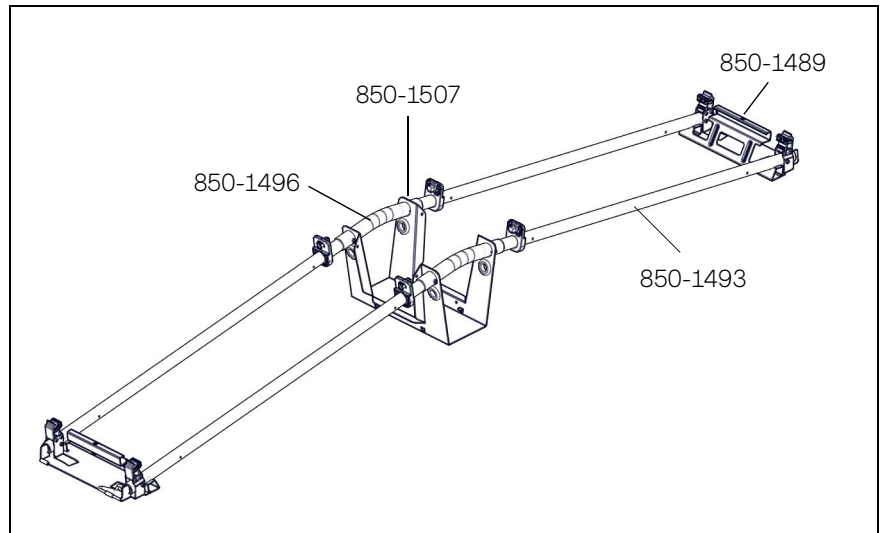
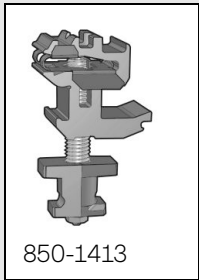
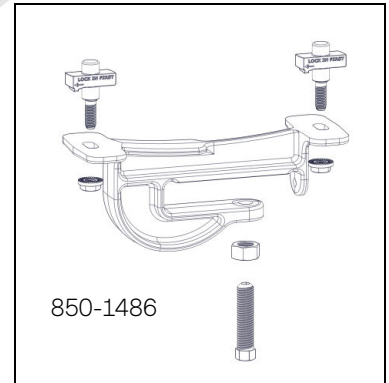
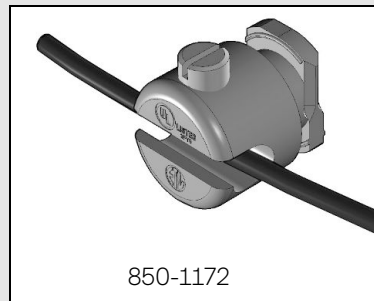
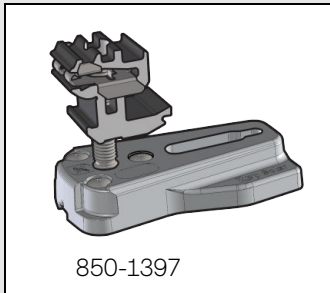

Q.PEAK DUO-G5/TS, Q.PEAK DUO BLK-G5/TS Installation Supplement for Zep Compatible PV Mounting Solutions

Hanwha Q CELLS America Inc.

Based on Zep Solar Document No.
800-1444-001 Rev G

File Generated July 6, 2020

Notices

This manual contains important installation instructions for the core hardware components required for mounting Zep Compatible™ PV arrays.

WARRANTY VOID IF NON-ZEP-CERTIFIED HARDWARE IS ATTACHED TO GROOVE IN MODULE FRAME.

This supplement applies to Q.PEAK DUO-G5/TS, Q.PEAK DUO BLK-G5/TS photovoltaic modules manufactured by Hanwha Q CELLS America Inc. ("Hanwha Q CELLS America Inc.") and is explicitly written for qualified professionals ("Installer" or "Installers"), including without limitation licensed electricians and NABCEP-Certified PV Installers. This document is intended to serve as a supplement to the Q.PEAK DUO-G5/TS, Q.PEAK DUO BLK-G5/TS Installation and User Manual from Hanwha Q CELLS America Inc.. Q.PEAK DUO-G5/TS, Q.PEAK DUO BLK-G5/TS modules feature a Zep Compatible groove in the aluminum frame to which hardware manufactured by Zep Solar, Inc. is directly connected.

For detailed instructions about the design and assembly of Zep Compatible systems, refer to the Zep Solar installation support tools available online at www.zepsolar.com.

Contents

1	Residential _____	5
1.1	Array Layouts and Design Loads, UL 61730 Requirements	6
1.2	Array Layouts, Design Loads, IEC Requirements	8
2	Commercial _____	9
2.1	ZS Beam Layout.....	10
2.2	ZS Peak Layout	11
3	Zep Compatible™ _____	12
3.1	Zep Groove and Rokit.....	12
3.2	Key and Tongue.....	13
4	Component Installation _____	14
4.1	Interlock Installation.....	14
4.2	Ground Zep Installation.....	20
4.3	Cam Foot Installation.....	21
4.4	Leveling Foot Installation.....	23
4.5	Beam Clamp Installation	25
4.6	Rokit Assembly Installation	27
4.7	Lock Block Installation.....	29
4.8	Electrical Layout.....	32
5	Array Bonding _____	34
5.1	Grounding Path Examples	35
5.2	Ground Path Example - ZS Beam.....	36
5.3	Ground Path Example - ZS Peak.....	37

1 Residential

Zep Compatible™ PV modules have been evaluated for design loads on the back surface (e.g., wind load) and on the front surface (e.g., wind and snow load) with the following Zep Solar solutions when installed with the Interlock and Leveling Foot or Cam Foot mounting hardware:

- ZS Comp
- ZS Tile
- ZS Span
- ZS Wave
- ZS Trap
- ZS Seam

The array layouts on the following pages show the maximum allowable spans and range of cantilevers that were evaluated with Zep Solar hardware in order for **Q.PEAK DUO-G5/TS, Q.PEAK DUO BLK-G5/TS Zep Compatible modules** to obtain the following load ratings using specified test procedures:

- **UL 61730 requirements:** 50 psf (2400 Pa) downward and upward design load (push/pull) for Landscape module orientation and 50 psf (2400Pa) downward and upward design load (push/pull) for Portrait module orientation
- **IEC 61215 requirements:** 75 psf (3600 Pa) downward and 33 psf (1600 Pa) upward design load, Landscape module orientation

Zep Solar hardware must be installed following all applicable instructions.

1.1 Array Layouts and Design Loads, UL 61730 Requirements

Figure 1.1 Layout With Leveling Feet, Landscape Example, 50 psf (2400 Pa) Design Load push/pull (safety factor 1.5)

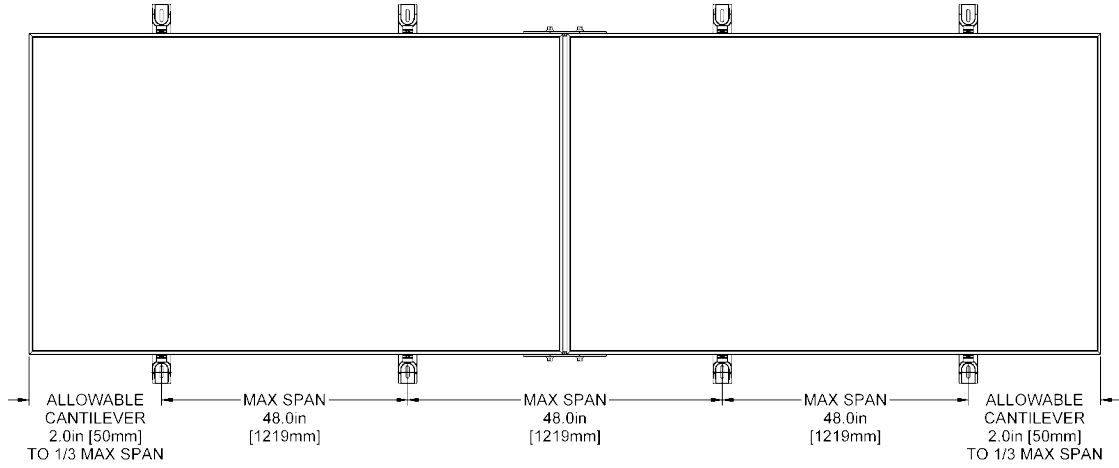

Figure 1.2 Layout With Leveling Feet, Portrait Example, 50 psf (2400 Pa) Design Load push/pull (safety factor 1.5)

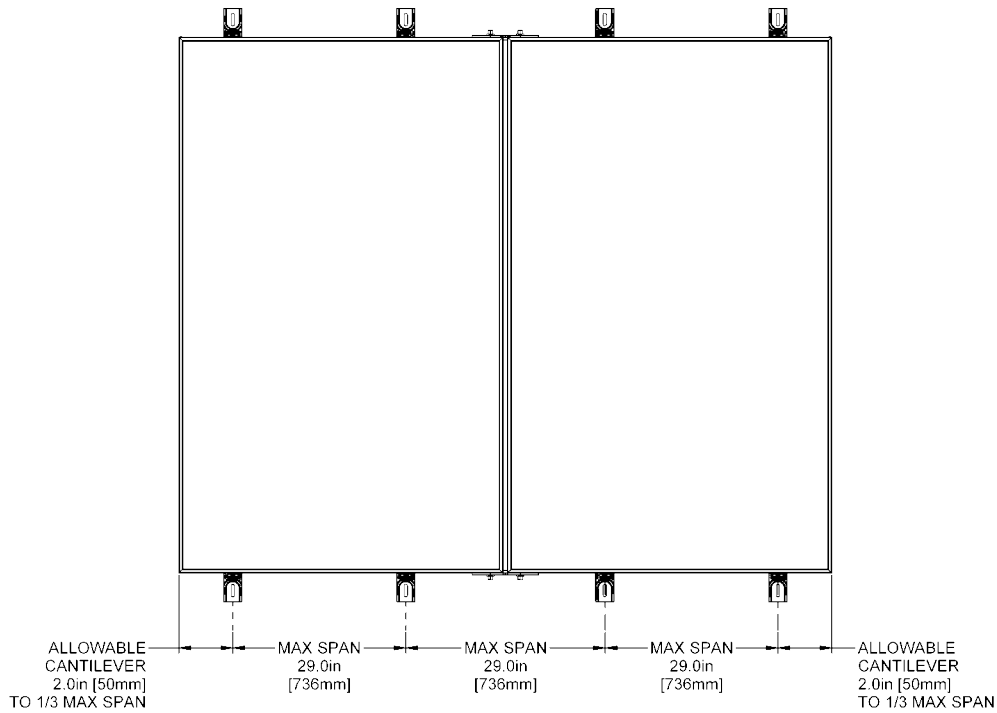

Figure 1.3 Layout With Cam Feet, Landscape Example, 50 psf (2400 Pa) Design Load push/pull (safety factor 1.5)

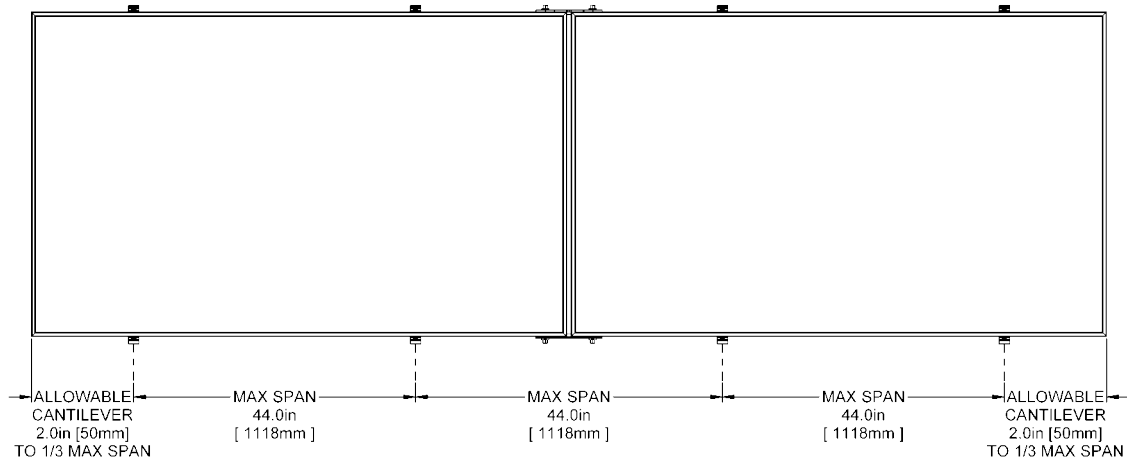
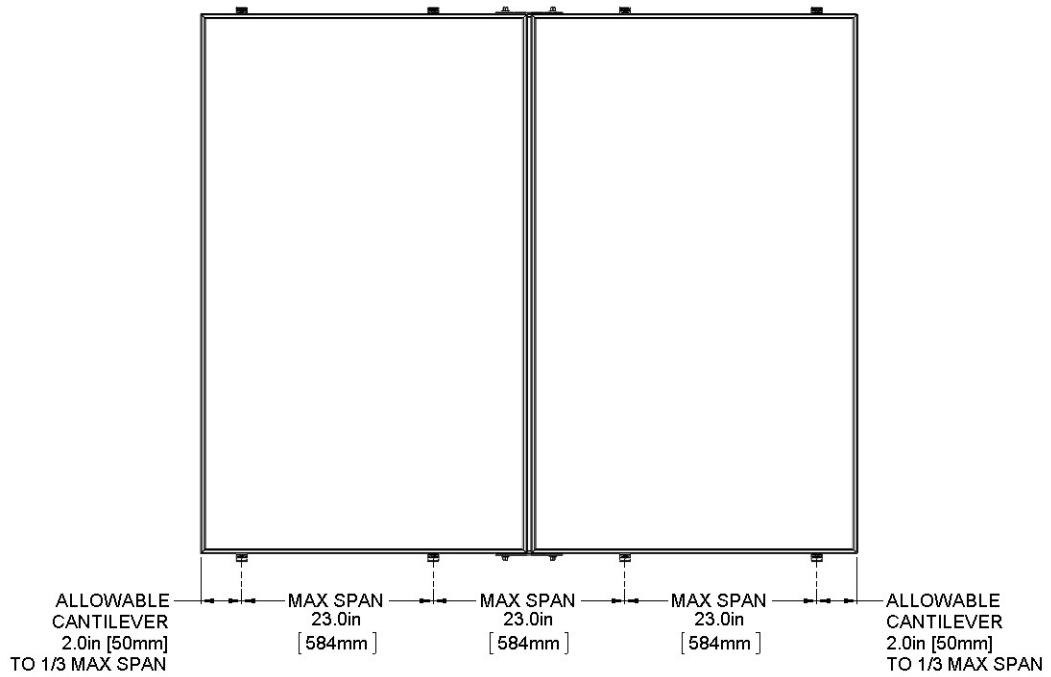

Figure 1.4 Layout With Cam Feet, Portrait Example, 50 psf (2400 Pa) Design Load push/pull (safety factor 1.5)



1.2 Array Layouts, Design Loads, IEC 61215 Requirements

Figure 1.5 Layout With Cam Feet, Landscape Example, 75 psf/33.4 psf (3600 Pa/1600 Pa)
Design Load push/pull (safety factor 1.5)

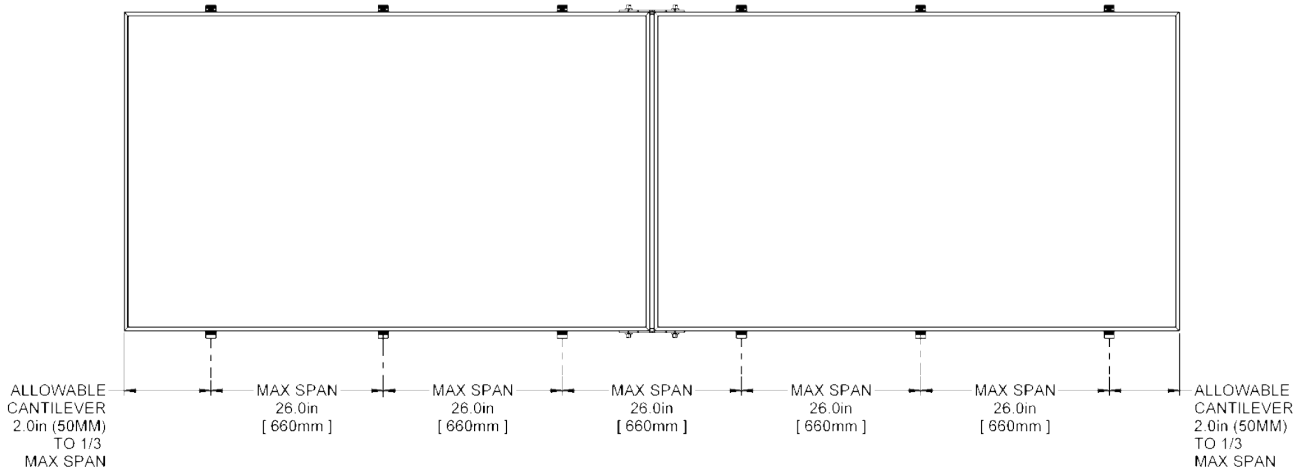
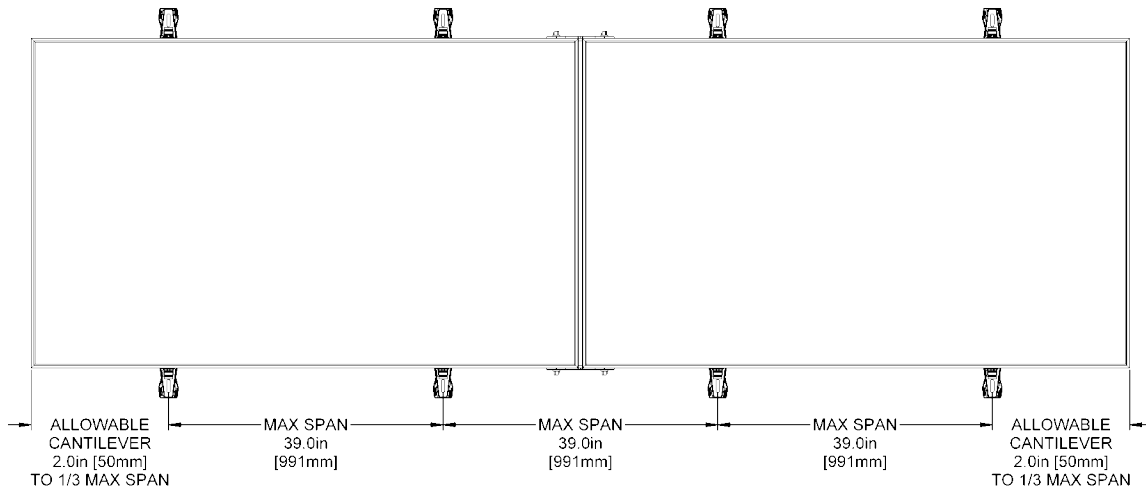

Figure 1.6 Layout With Leveling Feet, Landscape Example, 75 psf/33.4 psf (3600 Pa/1600 Pa)
Design Load push/pull (safety factor 1.5)



2 Commercial

Zep Compatible™ PV modules have been evaluated for design loads with a safety factor of 1.5 on the back surface (e.g., wind load) and on the front surface (e.g., wind and snow load) with the following Zep Solar commercial PV mounting solutions when installed with the mounting hardware specific to each solution:

- ZS Beam
- ZS Peak

The array layouts on the following pages were evaluated with Zep Solar hardware in order for **Q.PEAK DUO-G5/TS, Q.PEAK DUO BLK-G5/TS Zep Compatible modules** to obtain the following load ratings using specified test procedures:

- **UL 61730 requirements:** 50 psf (2400 Pa) downward and upward design load (push/pull).

Note: Zep Solar hardware must be installed following all applicable instructions.

2.1 ZS Beam Layout

Figure 2.1 ZS Beam Array Layout, 50 psf (2400 Pa) Design Load push/pull (safety factor 1.5)

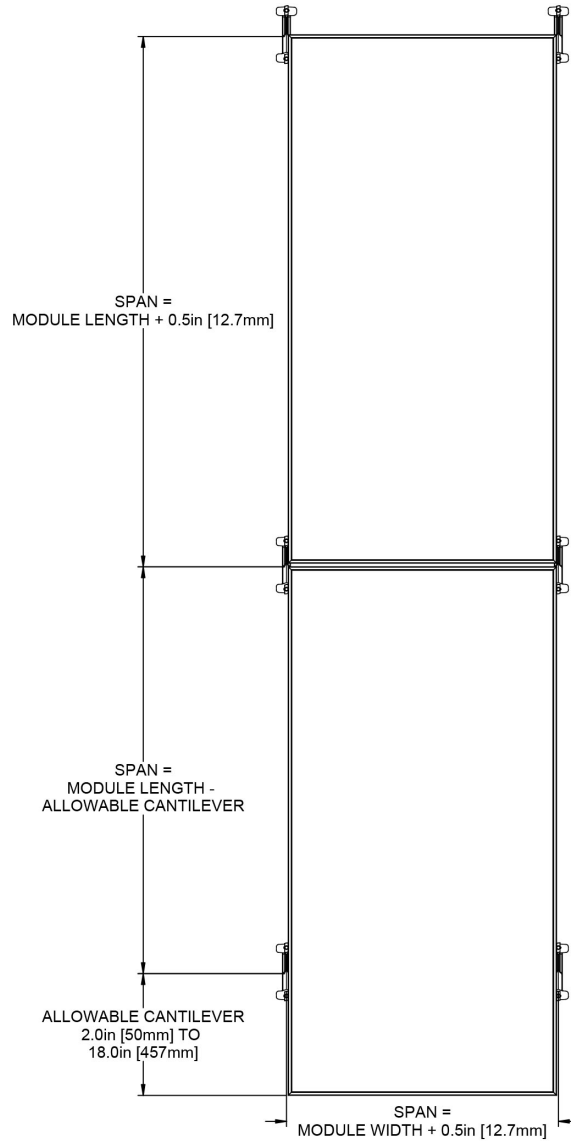

2.2 ZS Peak Layout

Figure 2.2 ZS Peak Array Layout, 50 psf (2400 Pa) Design Load push/pull (safety factor 1.5)

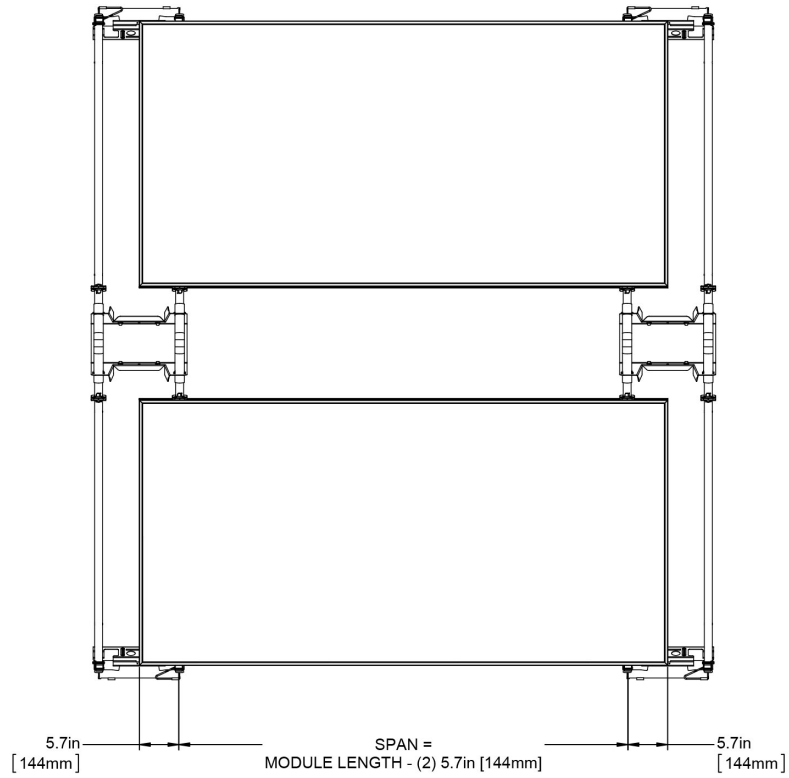

3 Zep Compatible™

Zep Solar mounting solutions are based on the Zep Groove, a patented module frame profile designed to mate easily and precisely with Zep components. Module frames with the Zep Groove are considered "Zep Compatible", and are manufactured according to specifications determined by Zep Solar, Inc.

3.1 Zep Groove and Rokit

Figure 3.1 Zep Groove and Rokit

Residential

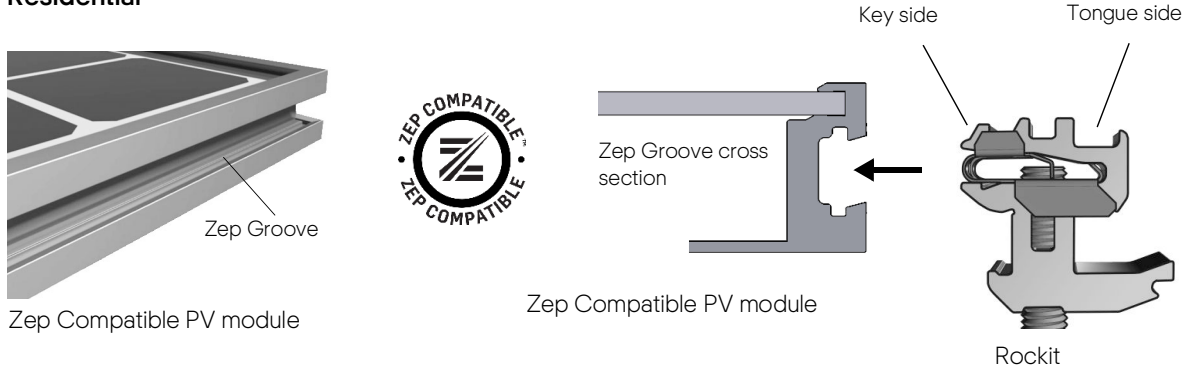

The Rokit is a hardware feature used to secure PV modules to the roof attachments. The Rokit fits into the Zep Groove on both sides: The Key side inserts, while the Tongue side receives.

Commercial

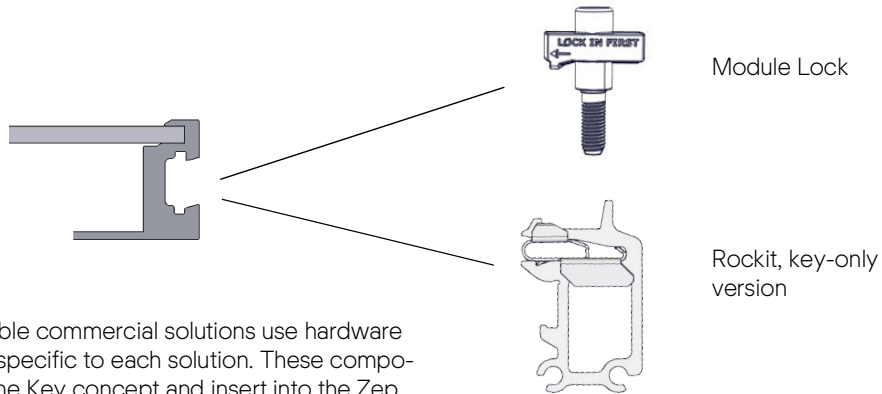

The Zep Compatible commercial solutions use hardware components that specific to each solution. These components also utilize the Key concept and insert into the Zep Groove.

3.2 Key and Tongue

The Key and Tongue concept informs all Zep Compatible designs. The Key side inserts into the Zep Groove, similar to inserting a key into a lock. On the other side, the Zep Groove allows PV modules to “drop in” easily onto the Tongue side.

3.2.1 Key and Tongue: Module Drop-In on Rockit

Figure 3.2 Module Drop-In Example

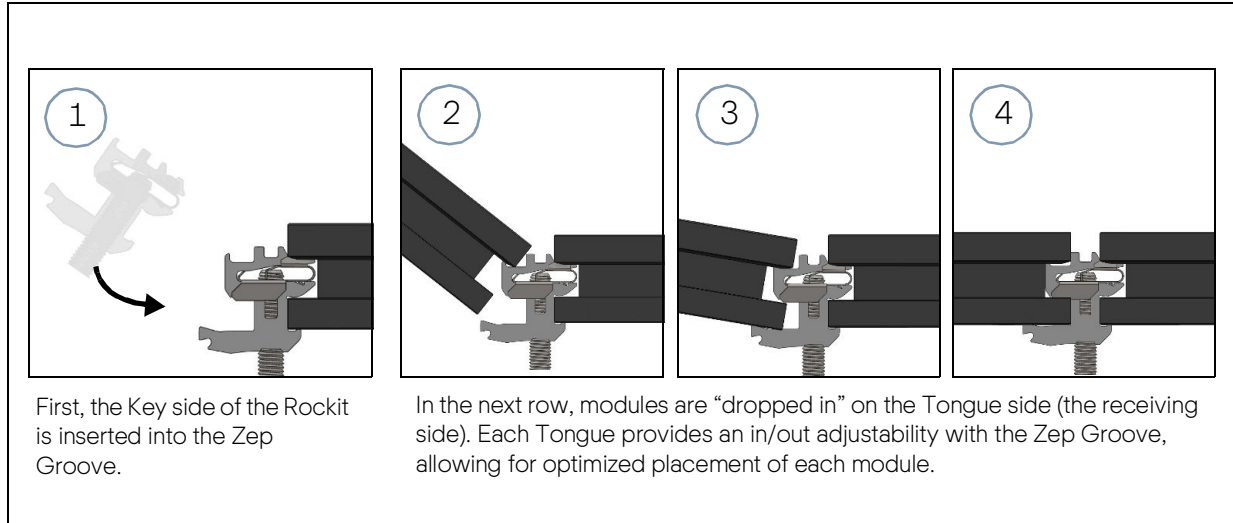

3.2.2 Key and Tongue: Interlock

Another example of the use of Key and Tongue in a Zep Compatible design is seen with the Interlock, a component that couples and bonds two modules together. Here, the Key and Tongue are differently shaped, but they still fit into the Zep Groove in the same manner as the Rockit. The Zeps are rotated 90 degrees to create the Key side bond with the module frame.

Figure 3.3 Interlock, Key and Tongue Side Views

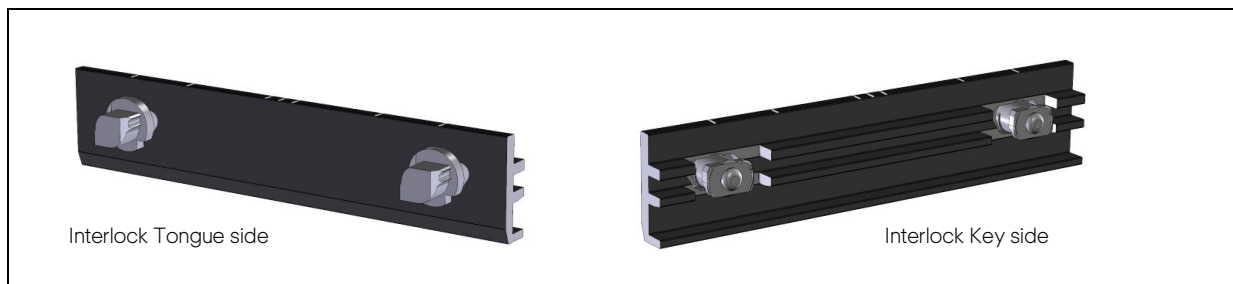

Other components which utilize the Interlock’s method of keying include:

- Ground Zep (all solutions)
- Lock Block (ZS Peak solution)

4 Component Installation

Zep Solar components are installed using precision-fitted, quarter-turn connections.

4.1 Interlock Installation

The Interlock provides module-to-module frame bonding through the interface with the Zep Groove. The Interlock is UL Listed to UL 2703.

Alignment marks along the top edge of the Interlock aid in module positioning and tightening of the fasteners.

Figure 4.1 Interlock Alignment Marks

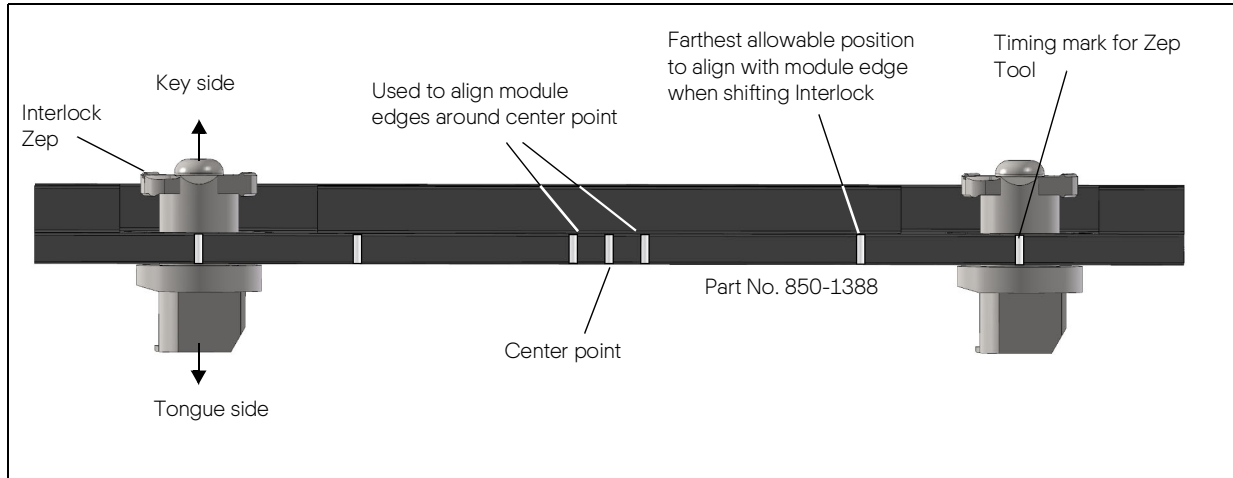

The Interlock is used to connect modules together.

Figure 4.2 Interlock Insertion

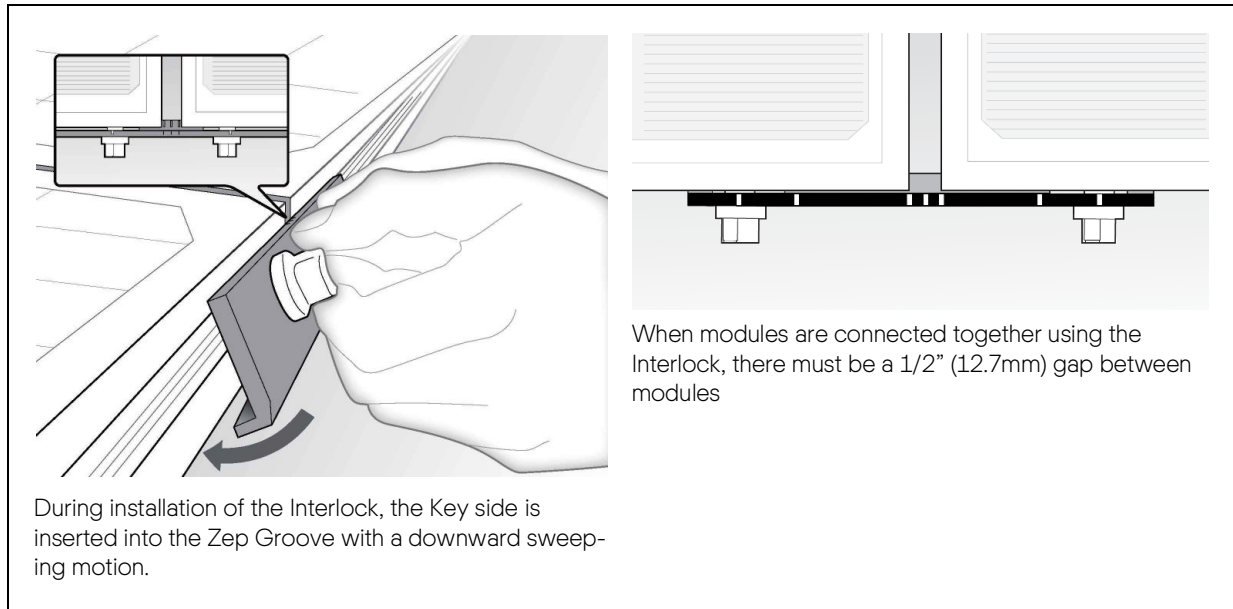

After the Interlock is inserted into the Zep Groove, the fasteners on the Interlock (the Interlock Zeps) are rotated to provide East-West module bonding.

Figure 4.3 Interlock Key Side Installation Uses Zep Tool

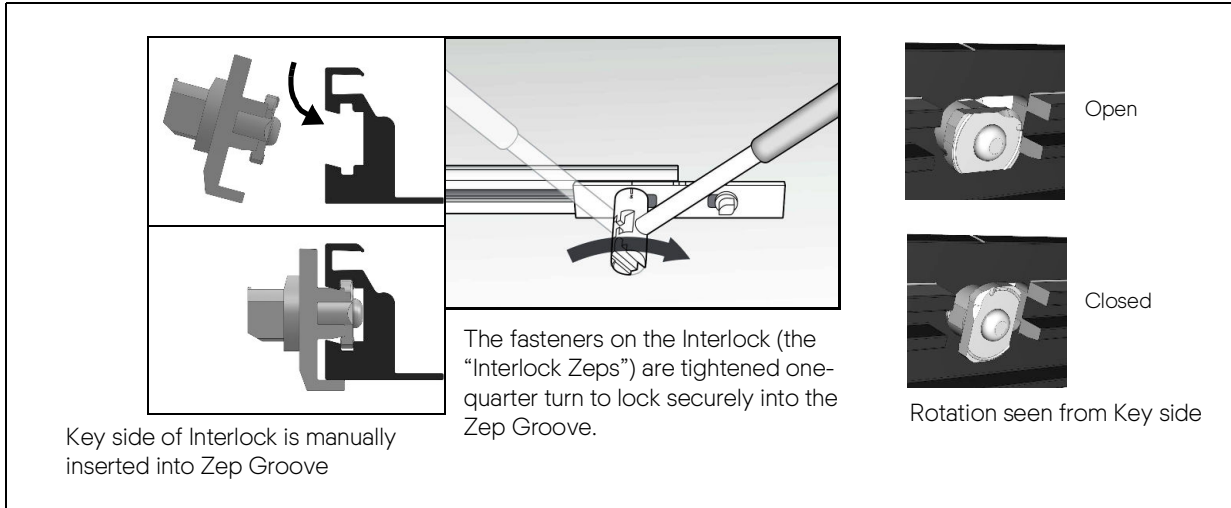

Alignment marks on the Interlock and the Zep Tool indicate exactly how far to rotate the Interlock Zeps to secure the Key side. Installers should not over-tighten or under-tighten.

Figure 4.4 Zep Tool Rotation Positions

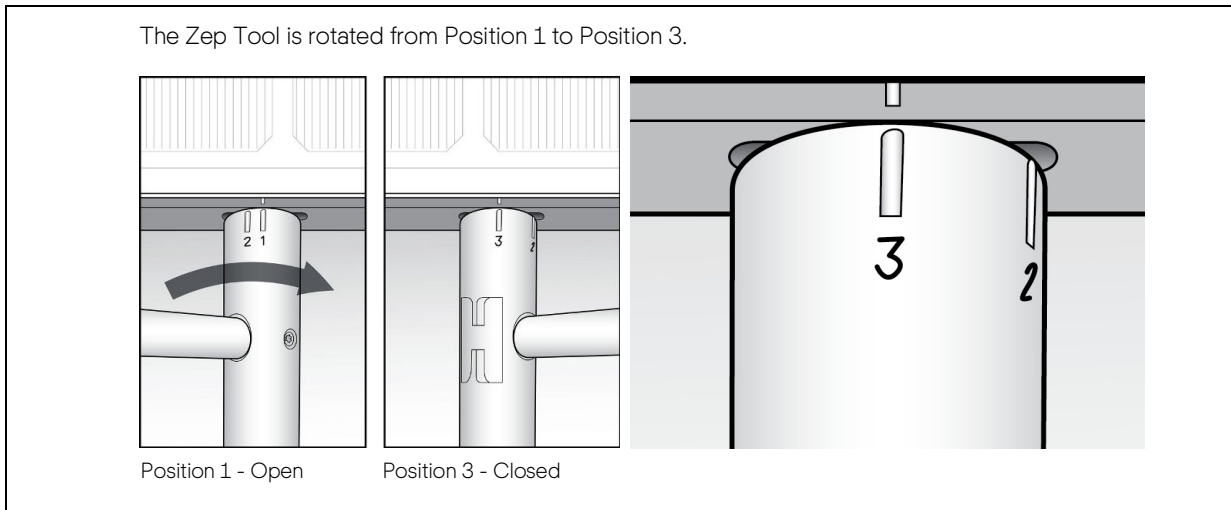

When the Interlock Zeps are rotated to the closed position (Position 3), they are also in the correct position to receive a module drop-in on the Tongue side. The difference between positions is easily visible.

Figure 4.5 Interlock Zeps Showing Open and Closed Position

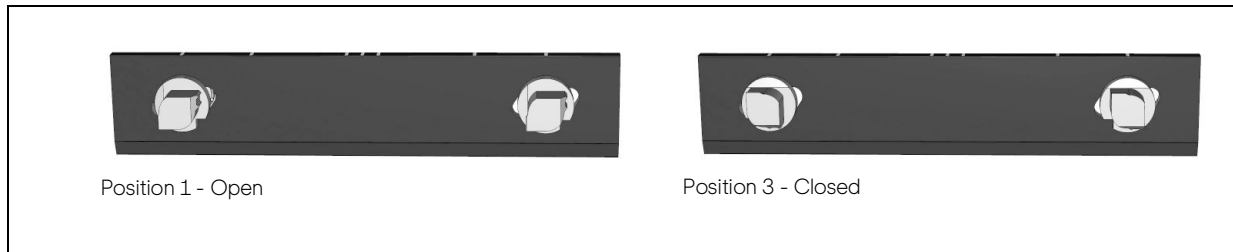

After the Interlock Zeps are secured on the Key side, the next row of modules is dropped-in on the Tongue side to provide North-South bonding within the array.

Figure 4.6 Module Drop-In on Interlock Tongue Side 1

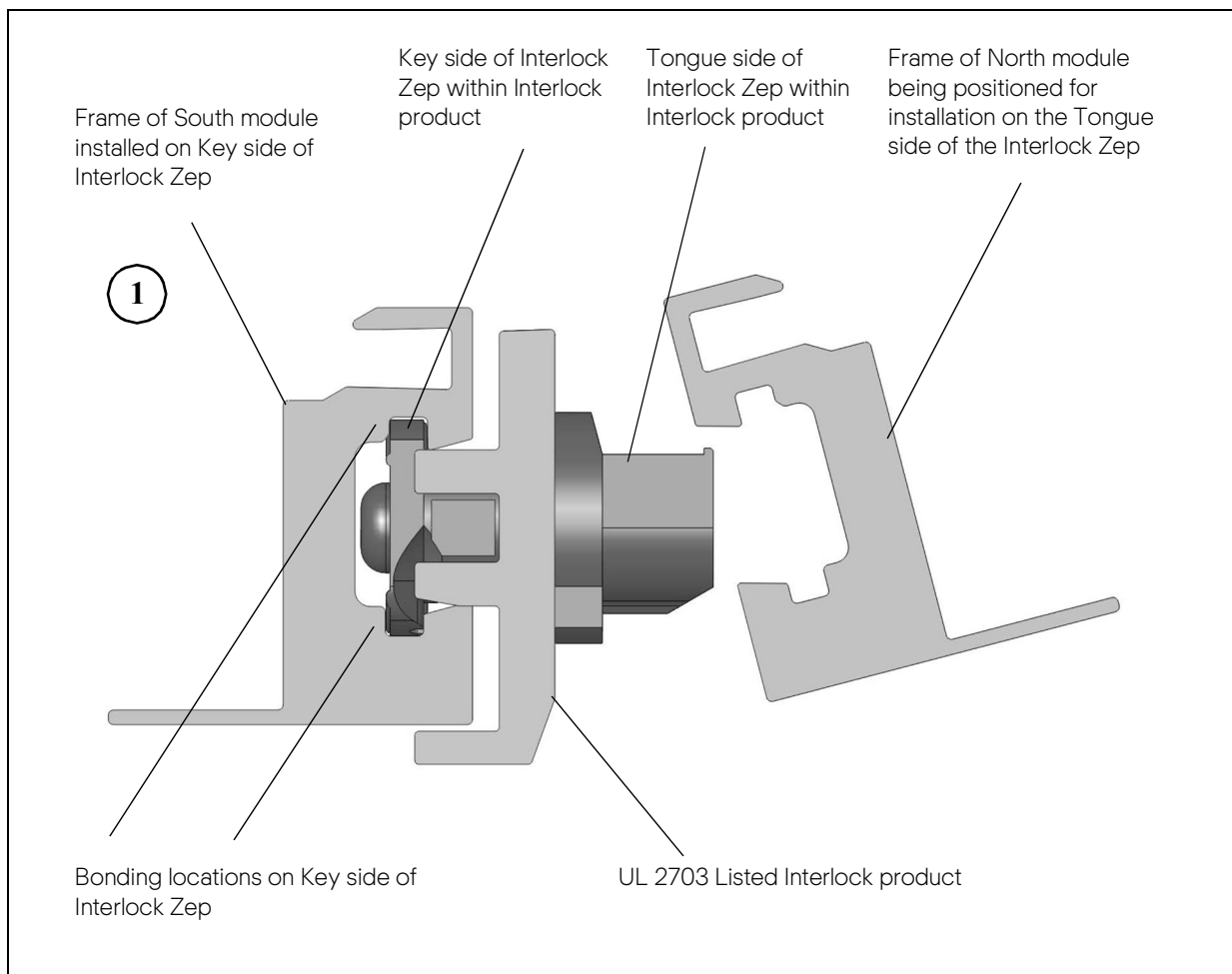

Figure 4.7 Module Drop-In on Interlock Tongue Side 2

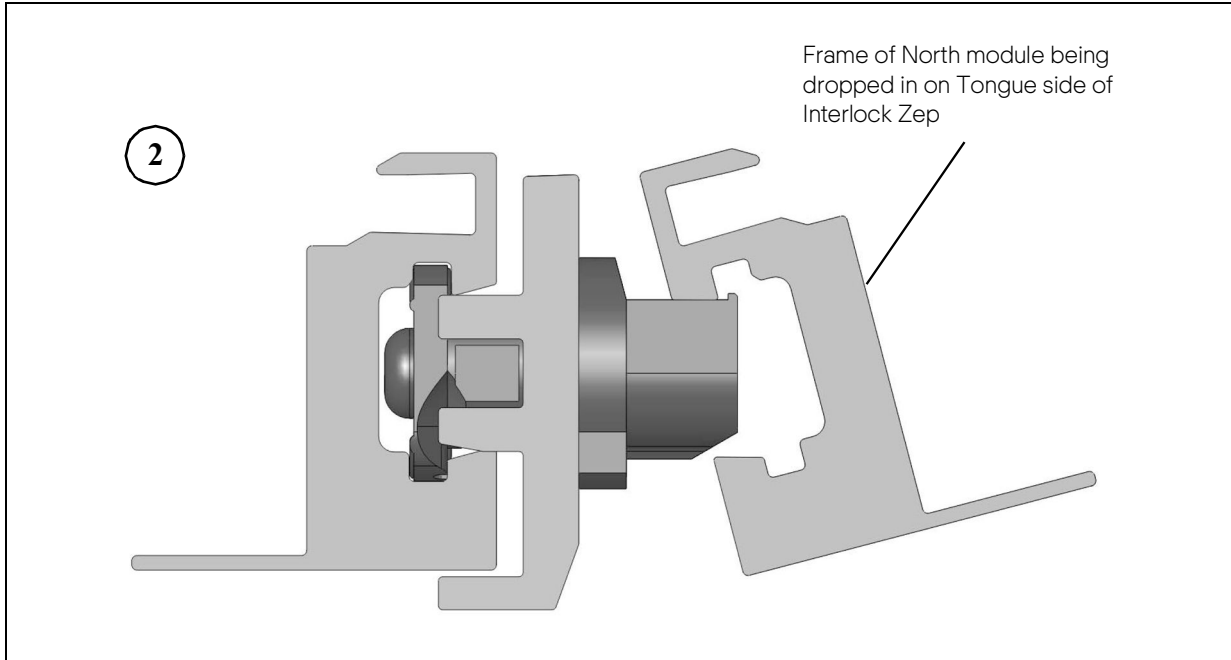

Figure 4.8 Module Drop-In on Interlock Tongue Side 3

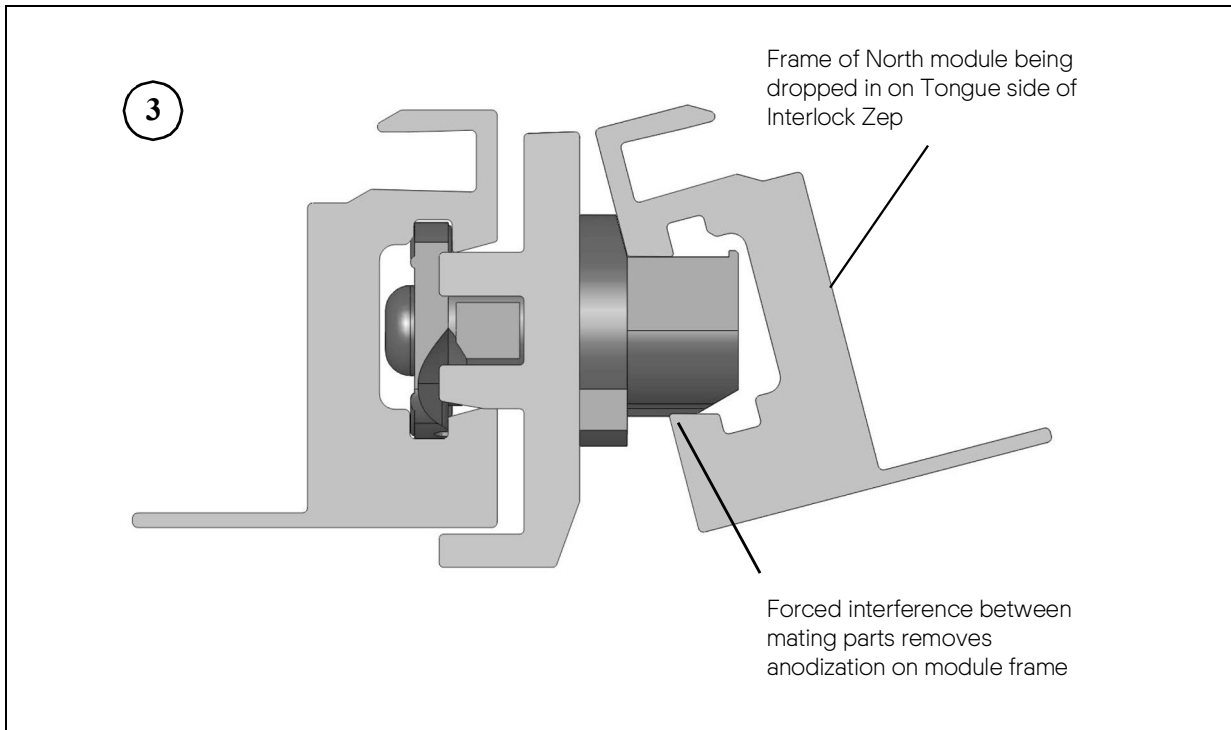
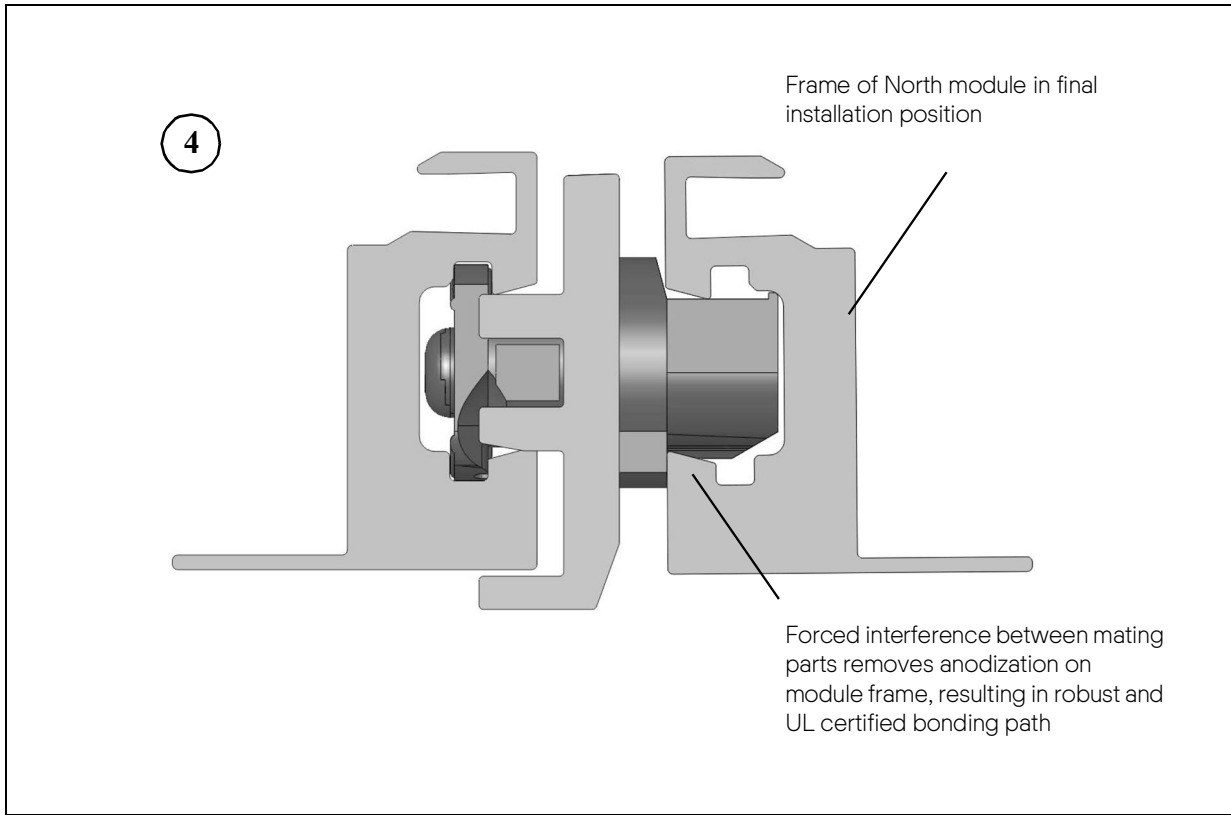

Figure 4.9 Module Drop-In on Interlock Tongue Side 4



4.2 Ground Zep Installation

The Ground Zep is used to provide a path to ground for a Zep Compatible array. The Ground Zep is UL Listed to UL 467 and UL 2703.

Figure 4.10 Ground Zep Installation

1 Insert a Ground Zep Into Module

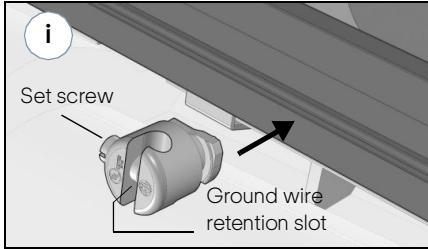

i

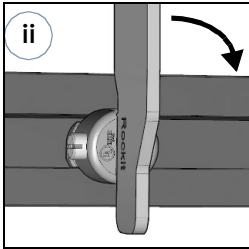

ii

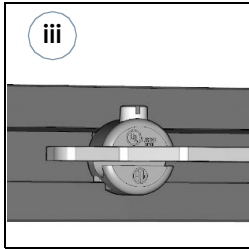

iii

Insert a Ground Zep in the Zep Groove of any module around the array perimeter.

Start with the set screw at 9 o'clock position (pointing left).

Using either the Zep Tool or the Flat Tool (shown), lock the Ground Zep into place by turning 1/4 turn clockwise. After the Ground Zep is turned 90 degrees, the set screw should be pointing straight up.

This locks the Ground Zep into the Zep Groove and creates a solid ground bond with the module frame.

2 Connect Ground Zep to Building Ground/Earth.

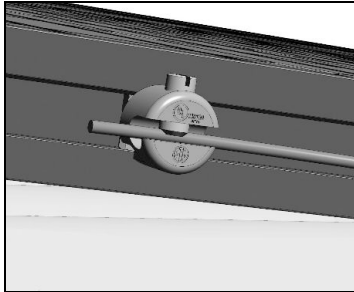

Insert solid copper ground wire into the ground wire retention slot and turn the set screw with a flat-bladed screwdriver until the ground wire is captured by the set screw. To fully secure, torque the set screw as follows:

- 14-10 AWG: 40 inch-lbs
- 8 AWG: 45 inch-lbs
- 6 AWG: 50 inch-lbs

4.3 Cam Foot Installation

The Cam Foot is used to connect Zep Compatible modules to a Zep Compatible roof attachment system. For ZS Span, the Cam Foot connects modules to Zep Solar Spanner Bars.

Figure 4.11 Cam Foot

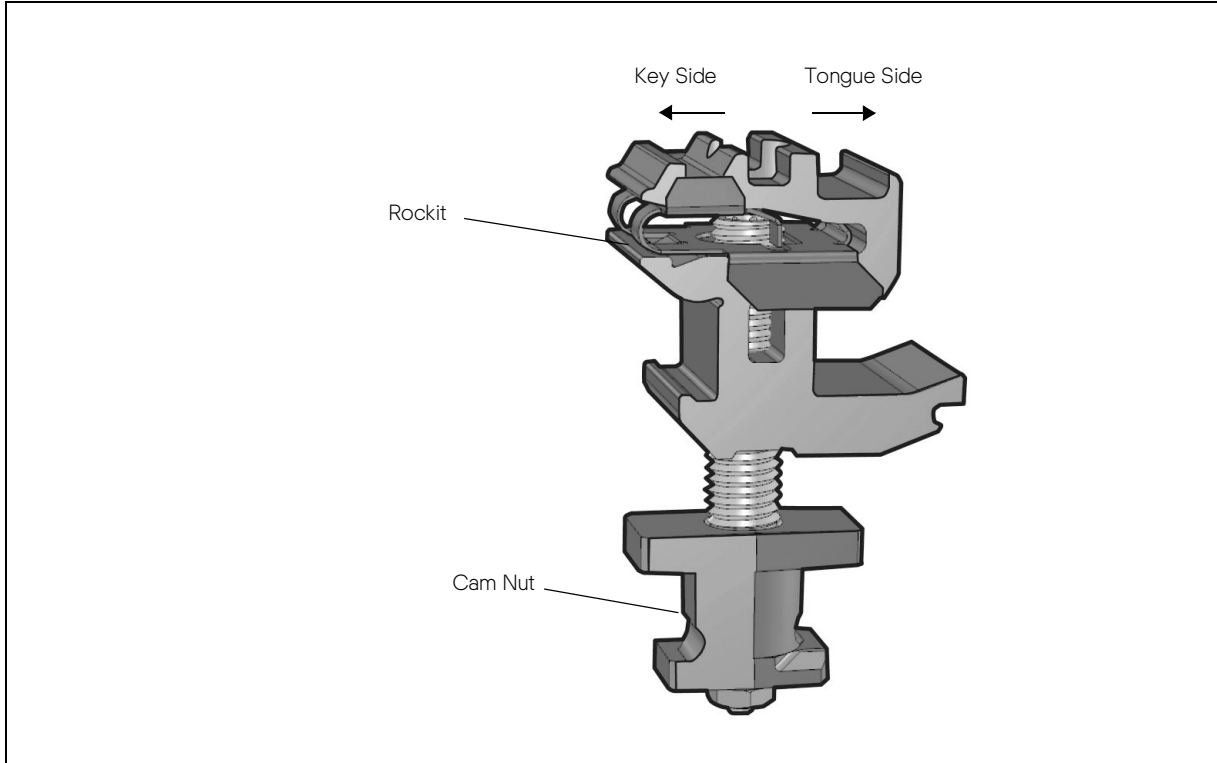
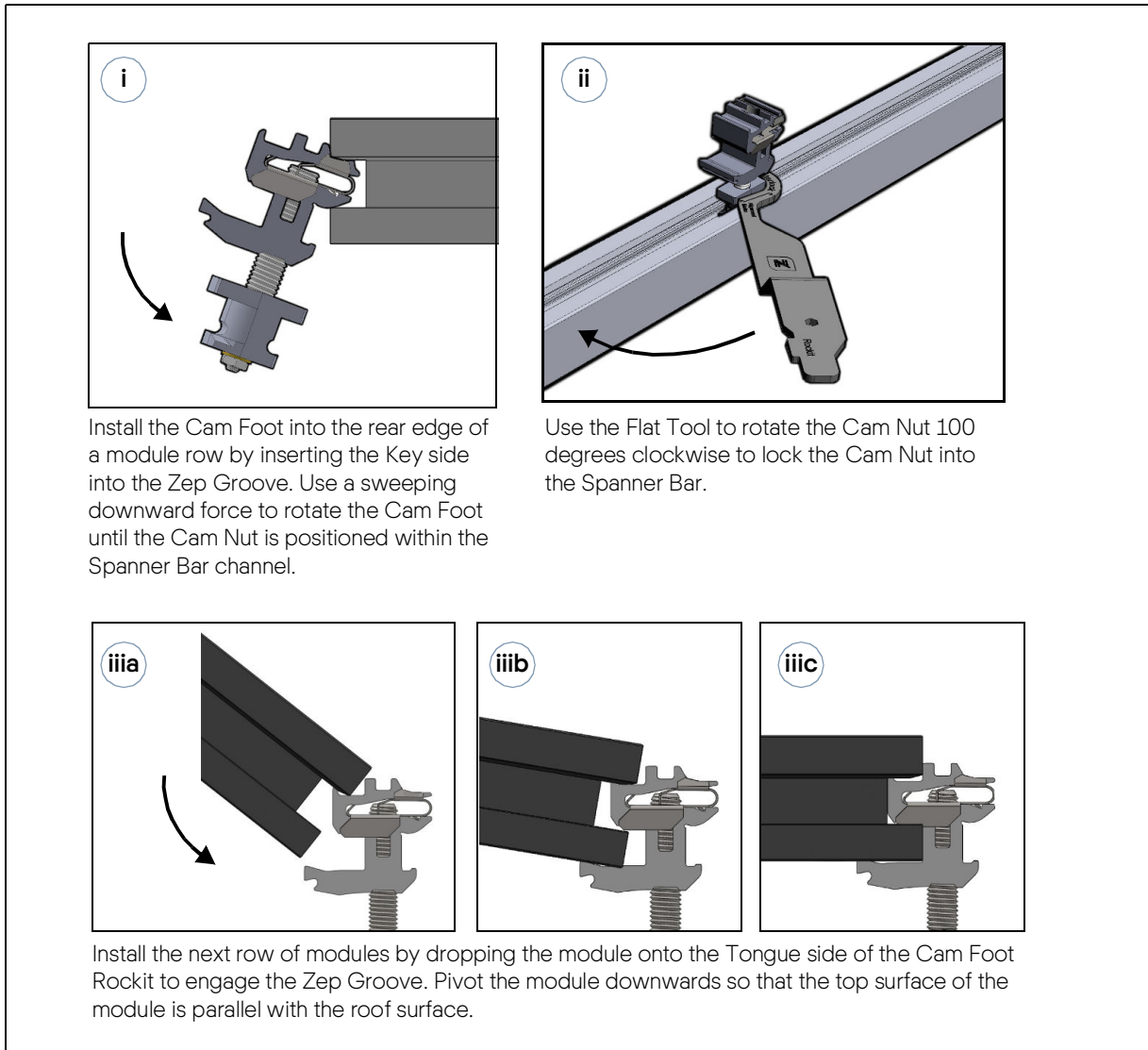

Figure 4.12 Cam Foot Installation - Zep Groove and Spanner Bar



4.4 Leveling Foot Installation

The Leveling Foot is used to connect Zep Compatible modules to a Zep Compatible roof attachment system. For ZS Comp, the Leveling Foot connects modules to Zep Solar Comp Mounts or Zep Solar-approved standoffs.

Figure 4.13 Leveling Foot

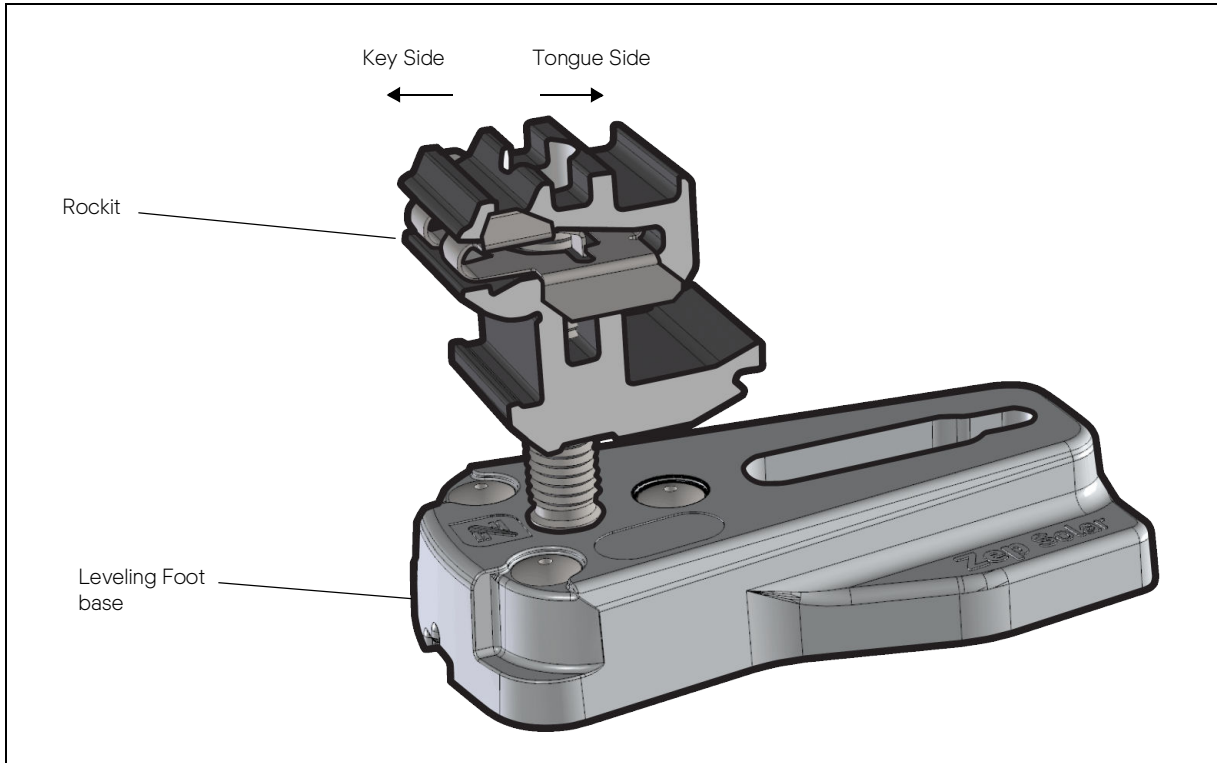
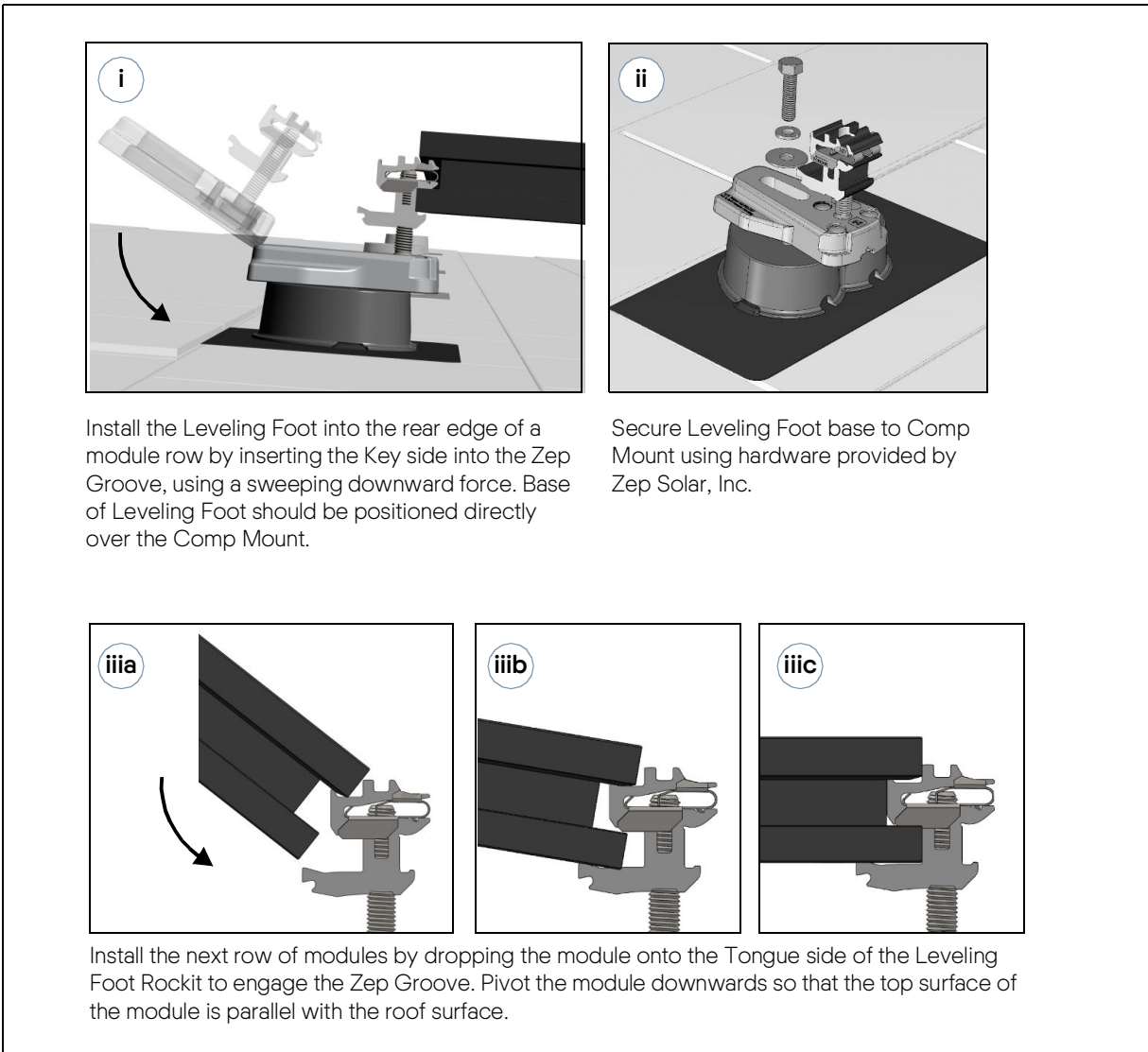

Figure 4.14 Leveling Foot Installation - Zep Groove and Comp Mount



4.5 Beam Clamp Installation

The Beam Clamp, used in ZS Beam, connects Zep Compatible modules to a Cee or Zee purlin within a solar support structure.

Figure 4.15 Beam Clamp

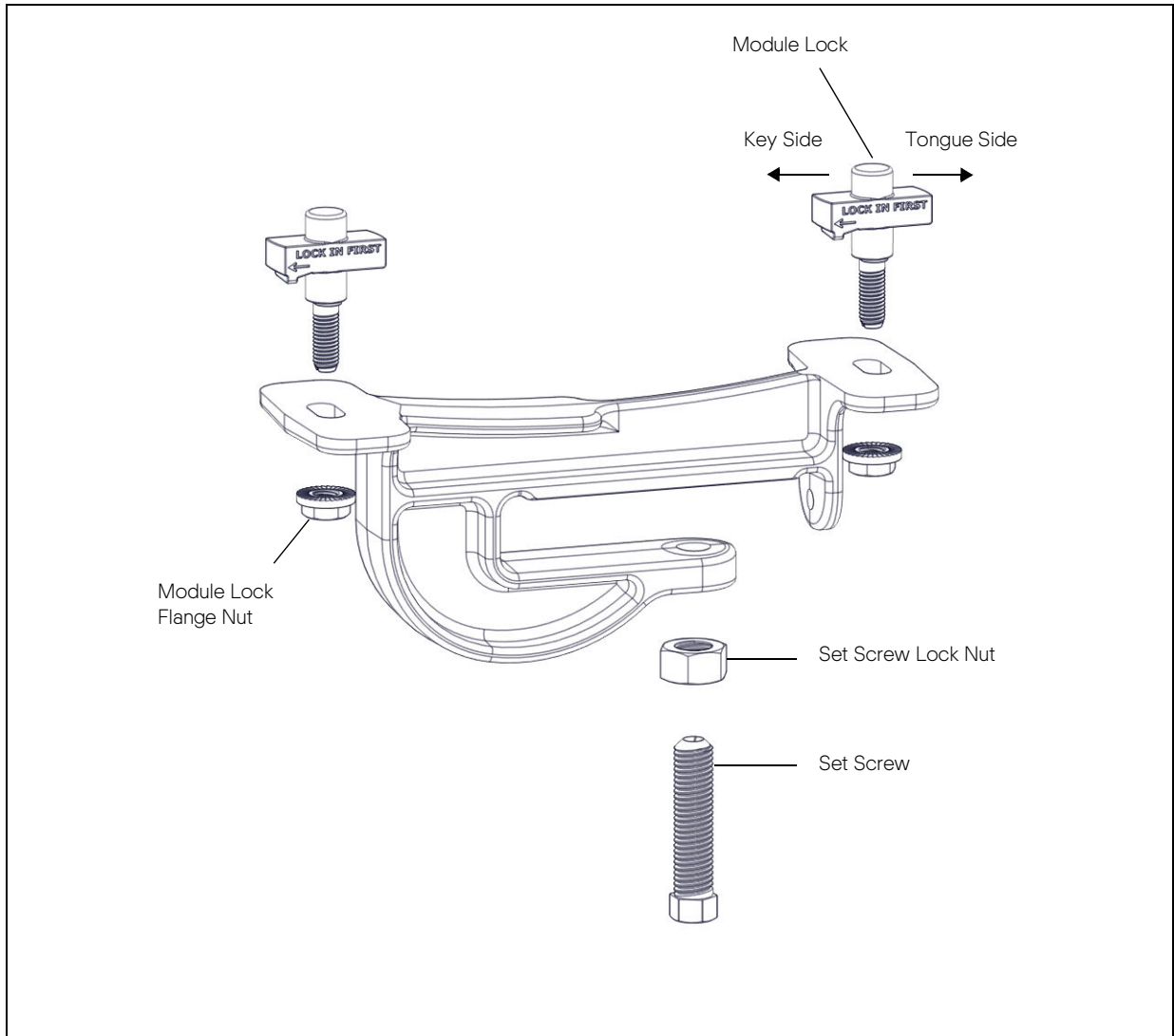
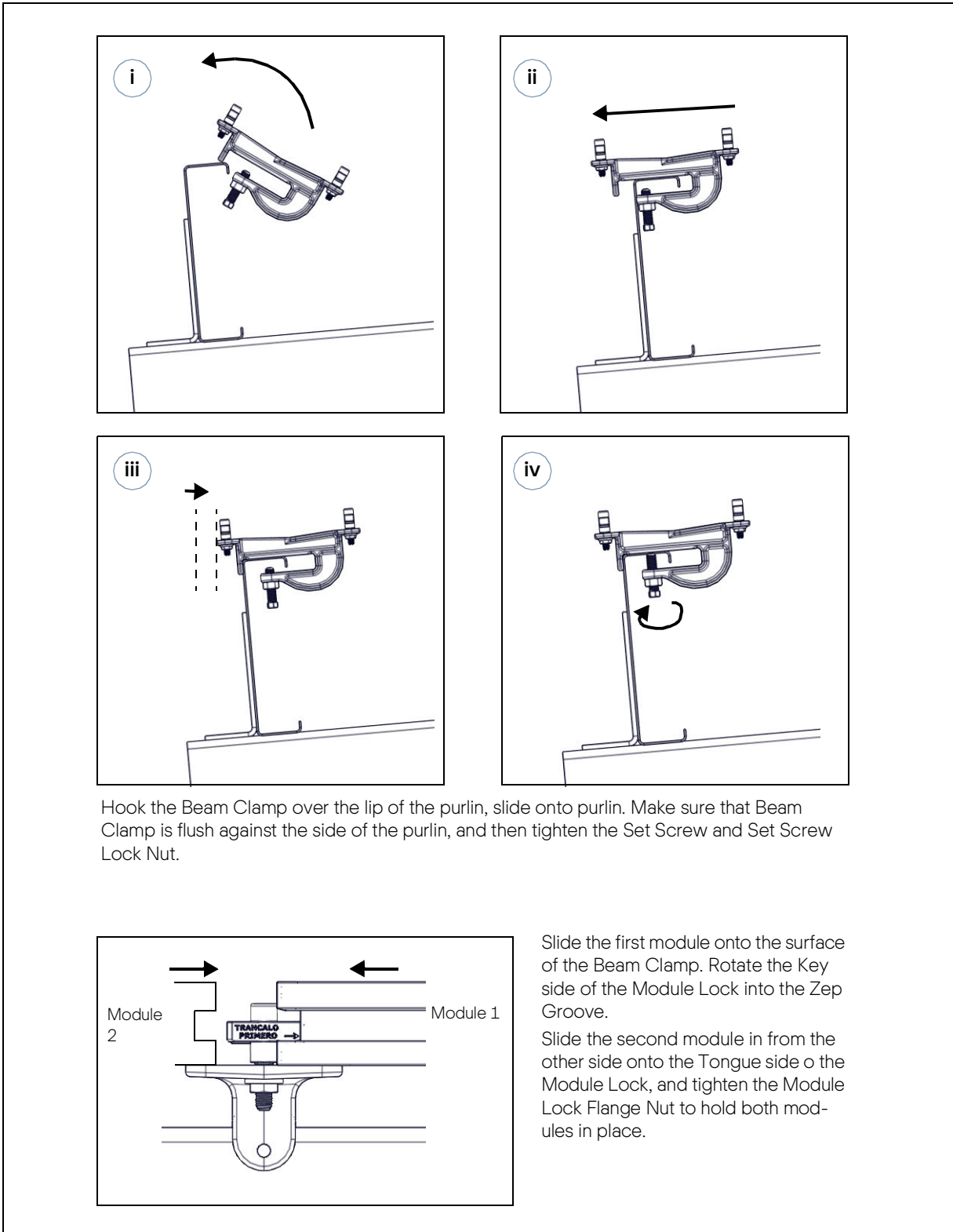

Figure 4.16 Beam Clamp Installation and Module Attachment



4.6 Rokit Assembly Installation

The Rokit Assembly is a feature found on the Valley Base component of ZS Peak.

Figure 4.17 Valley Base

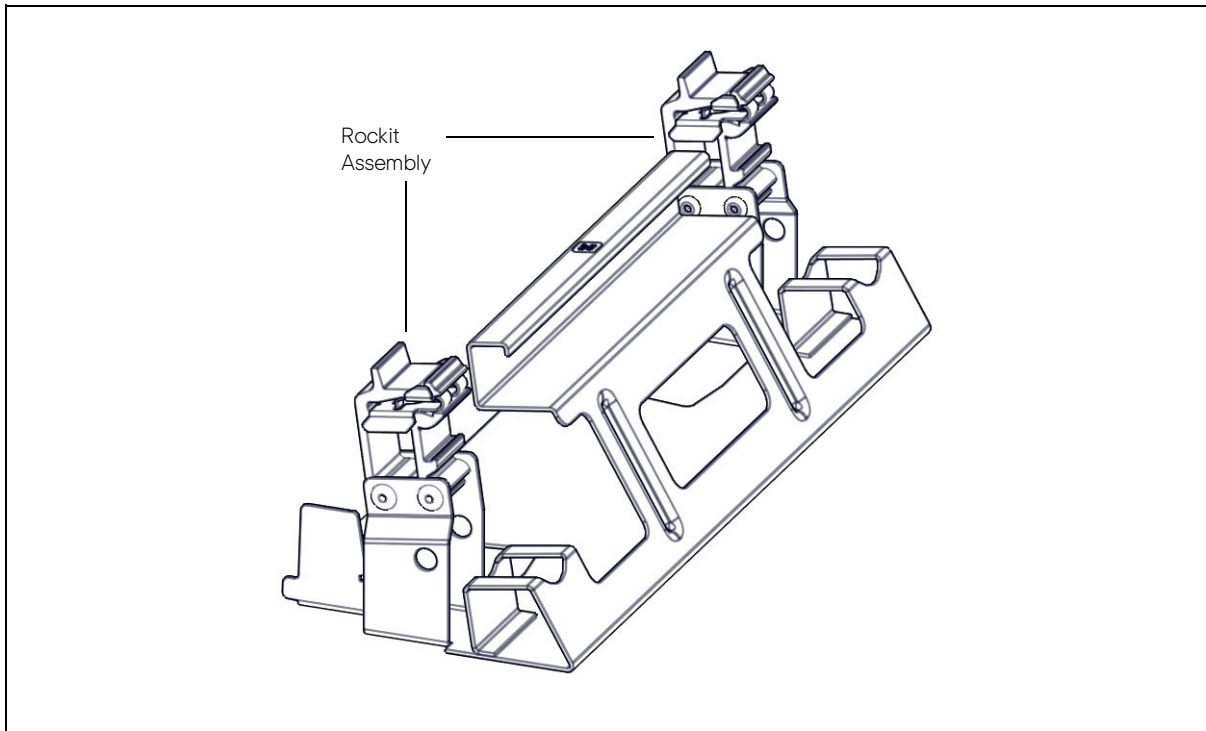
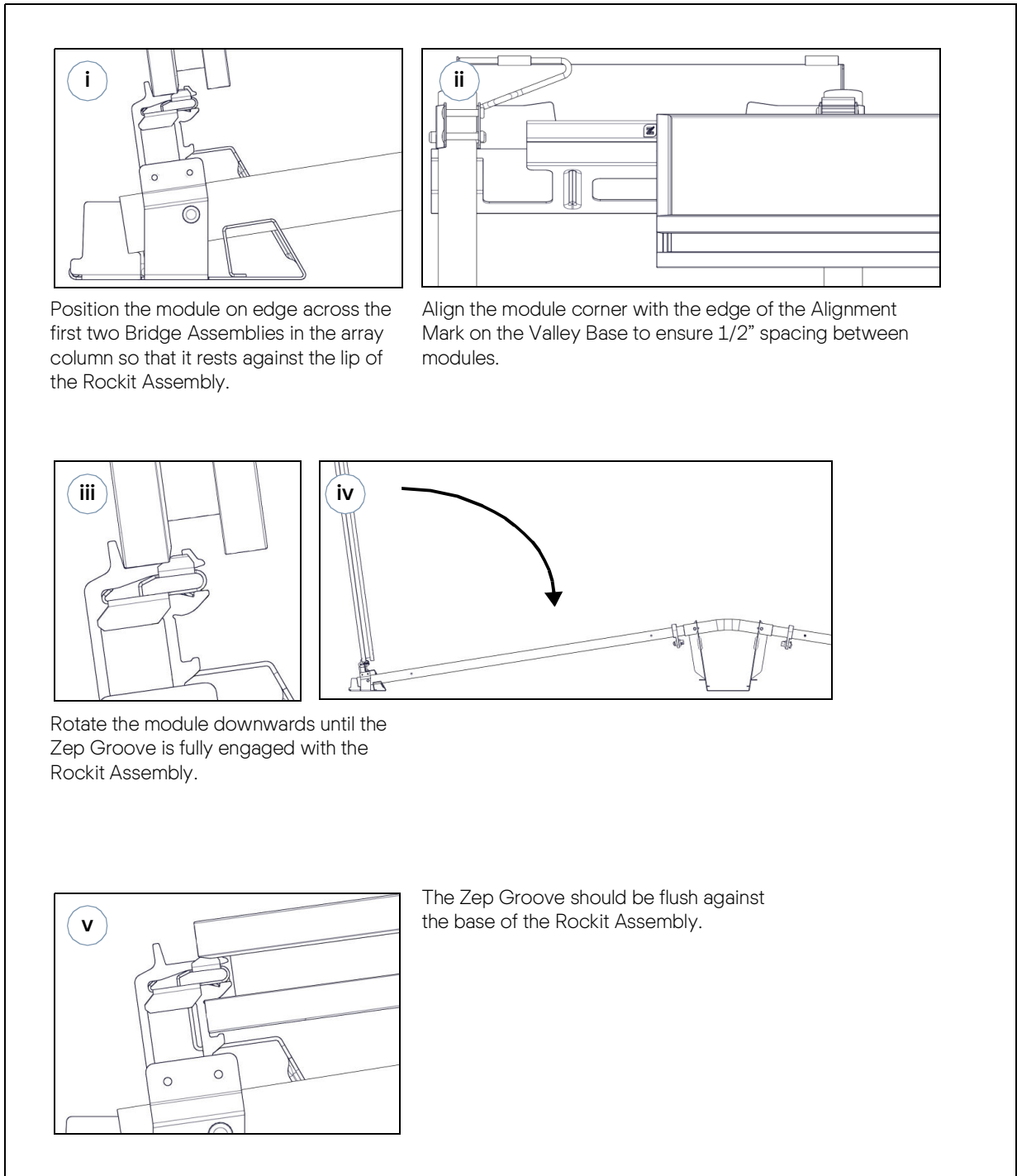

Figure 4.18 Module Attachment to Valley Base



4.7 Lock Block Installation

The Lock Block is a feature found on the Tube Assembly component of ZS Peak.

Figure 4.19 Lock Block on Tube Assembly

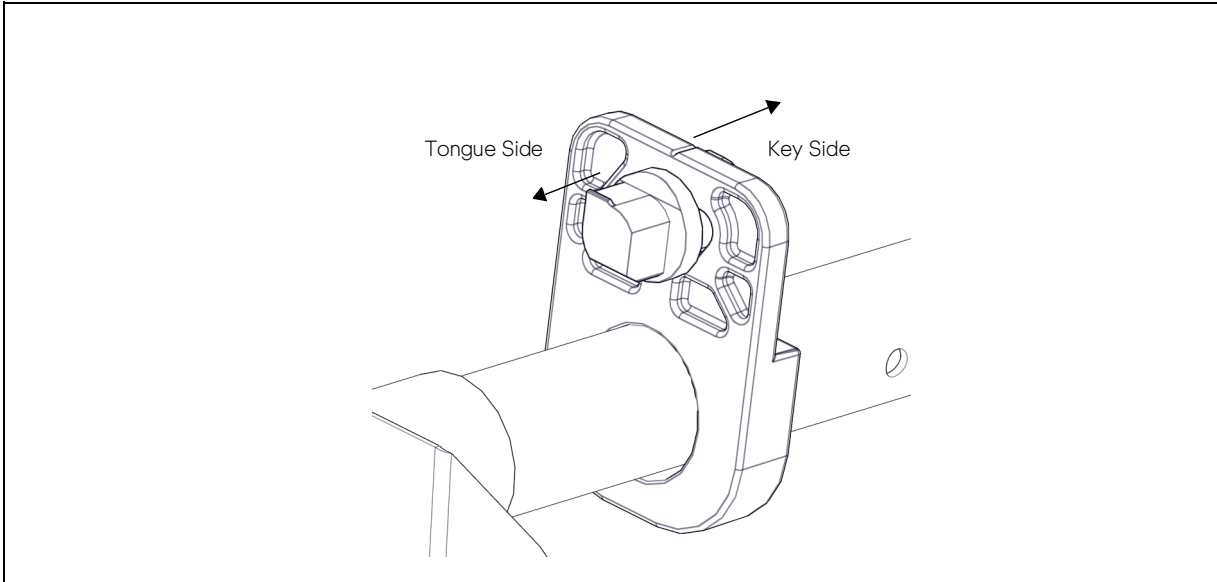
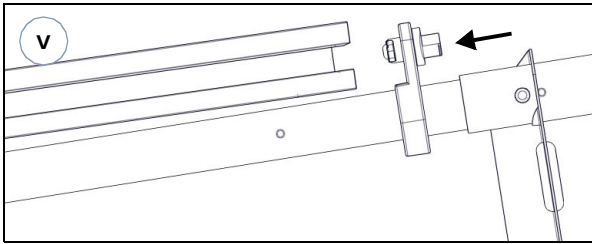
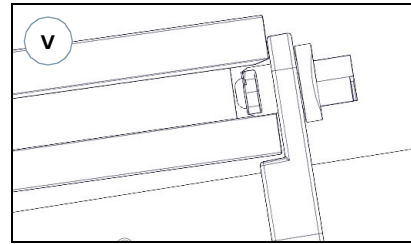

Figure 4.20 Connecting Lock Block to Module



On the other side of the module, move the Lock Block into position and insert the Key side of the Lock Block into the Zep Groove.



Ensure that the module frame sits securely on the shelf of the Lock Block.

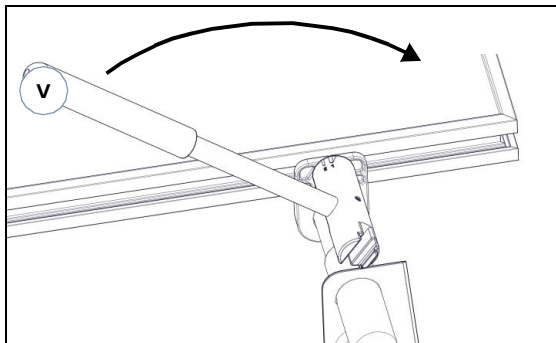

To secure the Lock Block, rotate the Zep Tool from Position 1 to Position 3, using the alignment marks on the Zep Tool and the Lock Block as a guide.

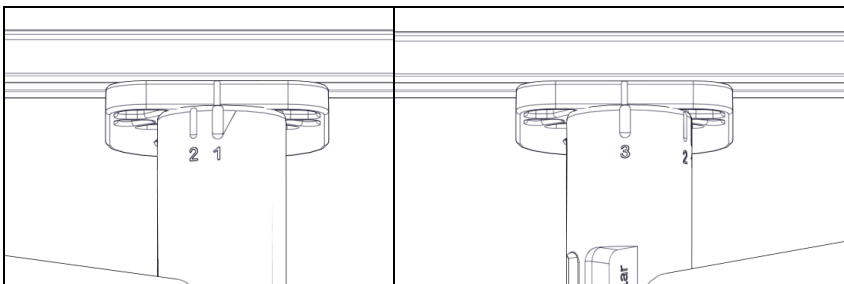

4.8 Electrical Layout

4.8.1 Module Selection

For detailed key electrical data, please refer to the actual data sheet referring to the relevant Module.

NOTE: For maximum energy yields, mismatches of specified electric current (IMPP) of more than 5 % should be avoided for all modules connected in series.

4.8.2 Safety Factor

During normal operation, a module may generate a greater current and / or higher voltage than that determined under standardized test conditions. Please use a safety factor of 1.25 for the following:

- Calculating the voltage measurement values (V_{oc}) of components
- Calculating the current measurement values (I_{sc}) of conductors
- Sizing of control systems connected to the outlets of the solar modules

NOTE: Please follow the valid national guidelines for the installation of electrical systems.

4.8.3 Series Connection

Connection of modules in series is only permitted up to the maximum system voltage as listed in the applicable data sheet of all the relevant modules to be installed.

NOTE: Take into account all possible operating situations and all relevant technical norms and regulations when designing the system. It has to be ensured that the maximum system voltage, including all necessary safety margins, is not exceeded.

NOTE: Take the voltage limit of the inverter into account when determining the maximum number of modules in the string.

4.8.4 Parallel Connection

Modules may be damaged by the occurrence of reverse currents (caused by module defects, ground leaks, or defective insulation).

NOTE: Ensure that the maximum reverse current load capacity indicated in the data sheet is met. In order to limit reverse currents that may occur, we recommend using the following safety options:

1) Layout with a limited number of parallel connected strings:

Without undertaking further current blocking measures, a maximum of two module strings may be operated in parallel on a single inverter or MPP tracker.

2) Layout with string fuses:

Place fuses for each string of modules at the plus and minus ends. Use gPV-fuses according to IEC 60269-6. Observe the maximum permitted number of strings as indicated in the specifications provided by the respective string fuse manufacturer and the technical guidelines.

NOTE: Ensure that the cabling is not under mechanical stress (Comply with bending radius of ≥ 60 mm).

NOTE: When installing different product versions, the lowest minimum permitted reverse current load capacity applies.

NOTE: Do not use light concentrators (e.g. mirrors or lenses).

5 Array Bonding

The Zep Compatible design concept allows the installer to build a hyper-bonded array with a single ground bond connection. In a hyper-bonded array, every module is structurally and electrically bonded to the surrounding modules, on all sides. The rotation of the Key side into the Zep Groove, and the dropping in of the next row of PV modules onto the Tongue side, acts to establish a bond for all UL listed components by cutting through the surface coating on the Zep Groove. This eliminates the need for extensive lengths of copper wire run to every module in order to ground the array.

5.1 Grounding Path Examples

The following examples show how a Zep Compatible PV array is hyper-bonded using Interlocks.

Figure 5.1 Grounding Path - Simple Array

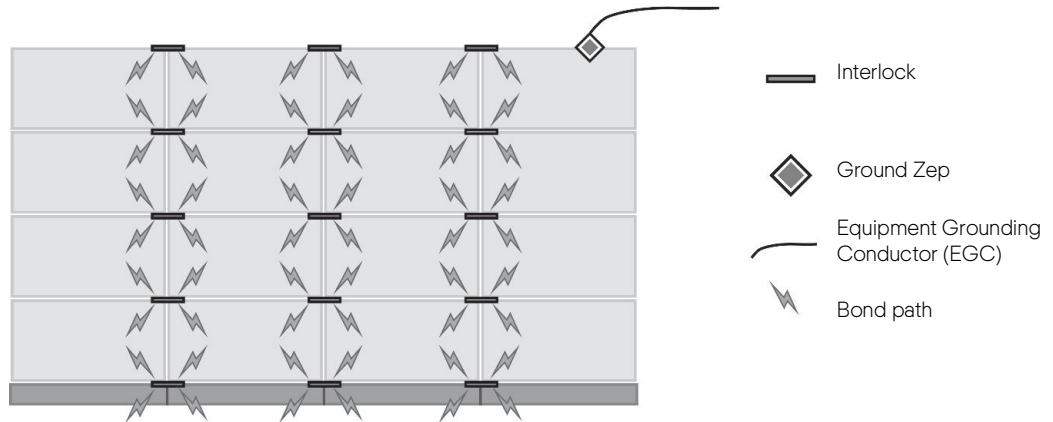

NOTE: If an array contains Thermal Expansion Joints, an additional Ground Zep may be required. Please refer directly to the Zep Solar installation manuals for further details.

5.2 Ground Path Example - ZS Beam

For ZS Beam, each module is structurally and electrically bonded to the surrounding modules via the Beam Clamps.

Figure 5.2 Grounding Path - ZS Beam

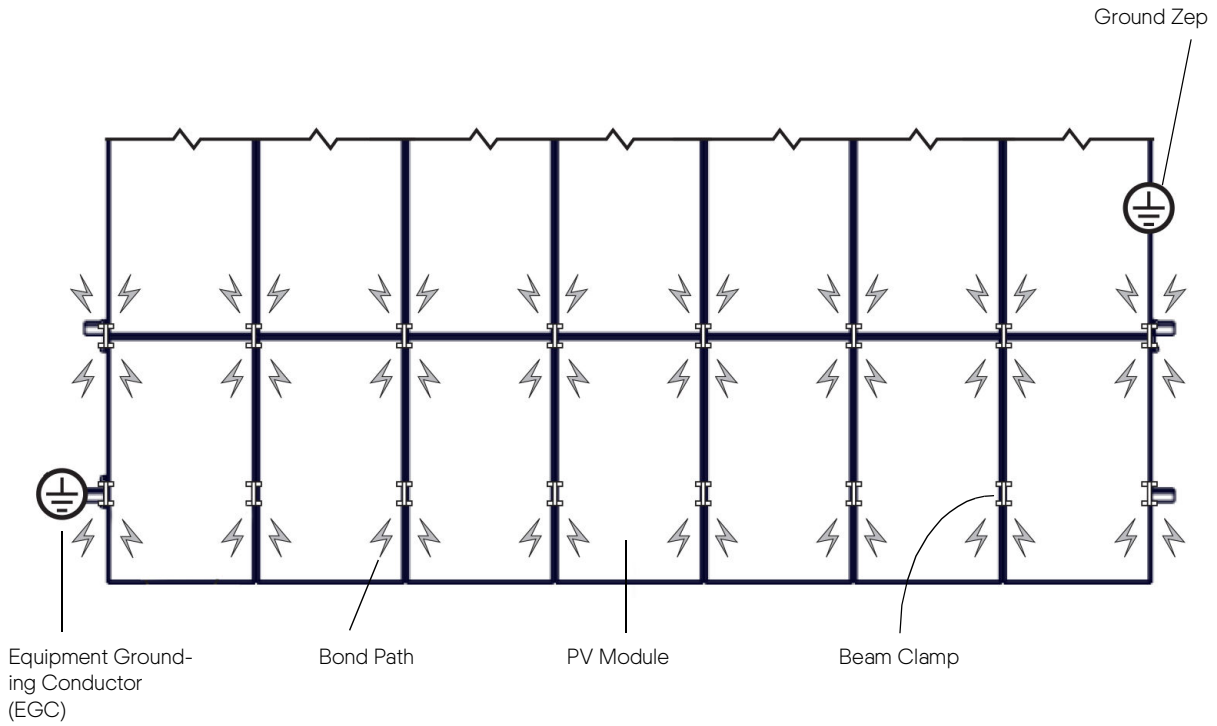

5.3 Ground Path Example - ZS Peak

For ZS Peak, each contiguous ZS Peak array is a single hyper-bonded matrix, including the Bridge Assemblies.

Figure 5.3 Grounding Path - ZS Peak

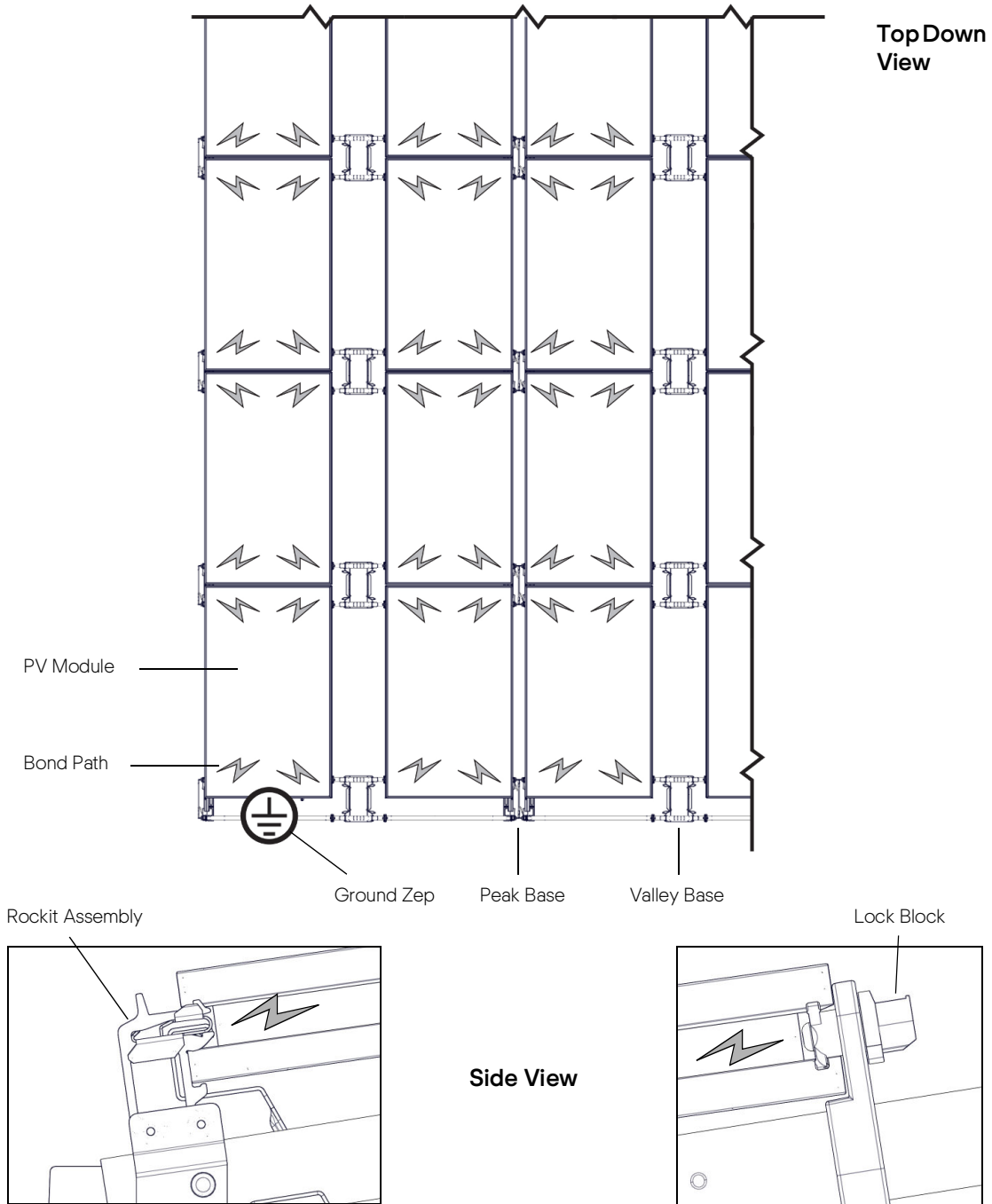

Hanwha Q CELLS America Inc.
400 Spectrum Center Drive
Suite 1400
Irvine, CA 92618, USA

www.q-cells.us
+1 (949) 748 59 96
inquiry@us.q-cells.com