

# **Qcells AC Module Installer FAQs**



# Table of Contents

GENERAL PRODUCT INFO .....3

WARRANTY AND REGISTRATION .....3

Q.OMMAND PRO APP..... 5

Q.HOME COMBINER (COMBINER BOX)..... 8

PANELS AND MICROINVERTERS..... 14

## General Product Info

### **Q1: What is Qcells AC Module?**

A: Qcells AC modules are Qcells' industry-leading solar panels combined with an integrated microinverter.

### **Q2: What Qcells product lines have AC modules?**

A: Both Q.TRON and Q.PEAK DUO are available as AC Modules.

### **Q3: What is the difference between Q.TRON and Q.PEAK?**

A: Q.TRON is Qcells' most advanced residential panel, with efficiency up to 22.5% and yields of up to 440Wp. Q.PEAK DUO is Qcells' best-selling residential solar panel, with efficiency up to 21.1% and yields of up to 415Wp.

## Warranty and Registration

### **Q4: What is the warranty term on the modules and microinverters?**

A: Qcells AC modules have a 25-year warranty on both the panel and microinverter.

### **Q5: When does the warranty on the system begin?**

A: The warranty begins when the site is created in the Q.OMMAND app.

### **Q6: The homeowner isn't present. Can I sign the customer agreement on their behalf?**

A: The customer agreement must be signed by the customer. The installer cannot sign on the customer's behalf.

**Q7: I forgot the activation code. How do I find it again?**

A: You can re-send the activation code using the Q.OMMAND Web app > Monitor > Site > Click the product in the list > System Settings > Installation > Scroll down to User Info > Click “Send Email” button > Inform the customer that a welcome mail has been sent to their pre-registered email address. That email will contain the activation code.

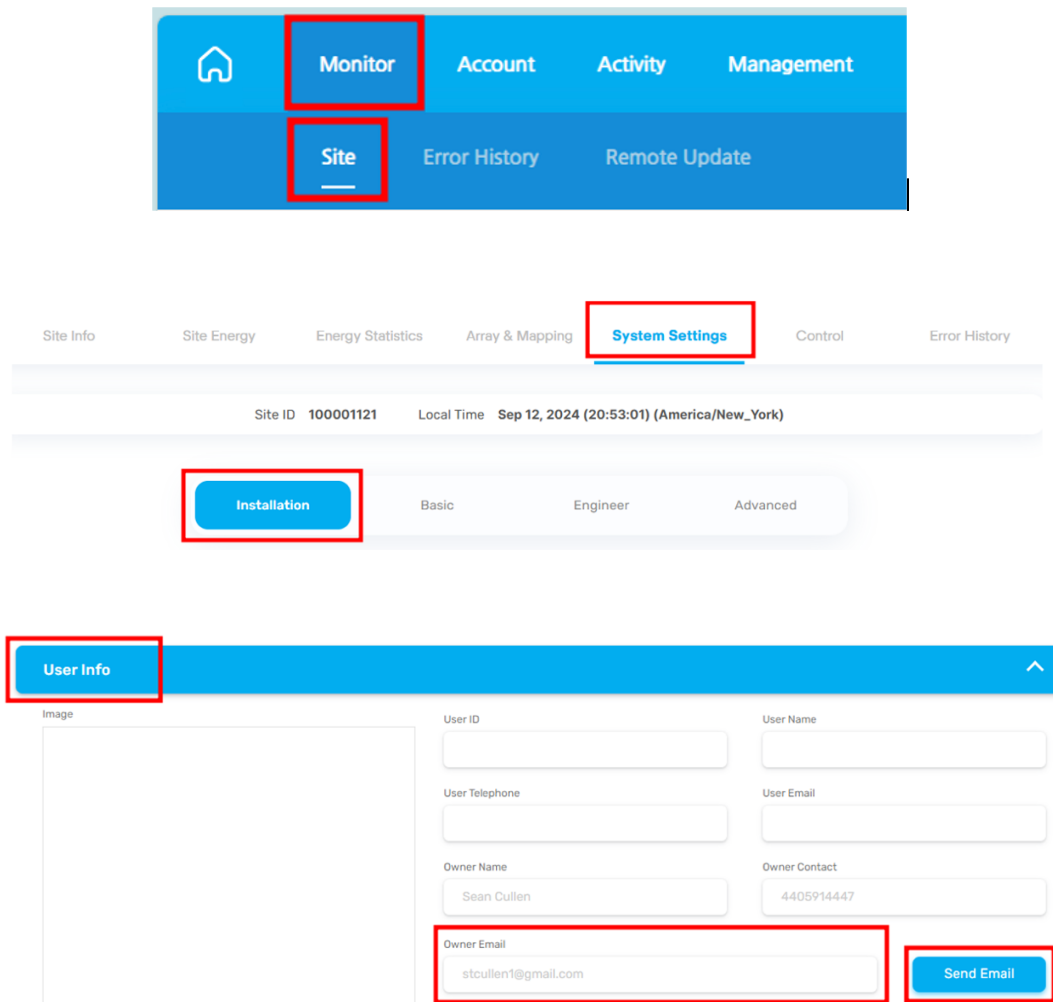

## Q.OMMAND PRO App

### **Q8: How do I download the app?**

A: You can download the Q.OMMAND PRO app through the Apple App Store, or Google Play Store.



Android



iOS

### **Q9: Why can't I download the app?**

A: Make sure your device is updated to the latest version.

### **Q10: Why can't I find my solar site in the app?**

A: Make sure the site is fully commissioned. If the error persists even after completing the commissioning process, reach out to Qcells Customer Support by calling 888-249-7750 or emailing [na.support@qcells.com](mailto:na.support@qcells.com).

### **Q11: Where do I find the activation code?**

A: The activation code is sent directly to the homeowner via email. You can send another email through the Q.OMMAND app.

Monitor > Site > Click the product in the list > System Settings > Installation > Scroll down to User Info > Click "Send Email" button > Inform the customer that a welcome mail has been sent to the pre-registered email address.

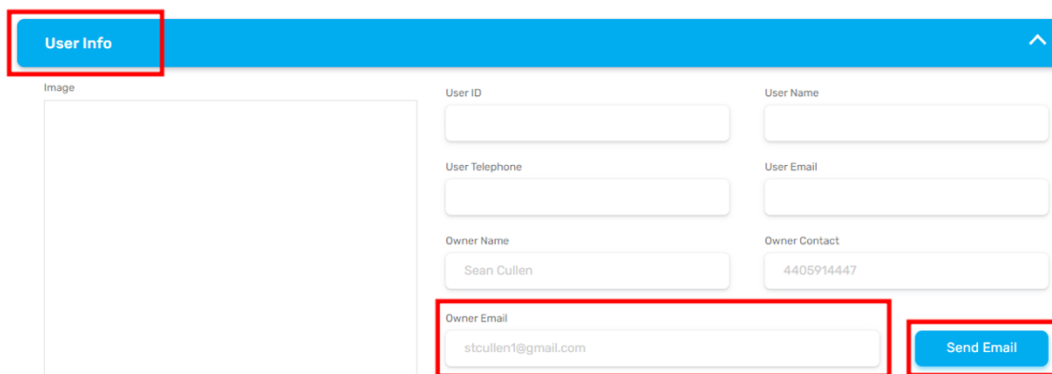
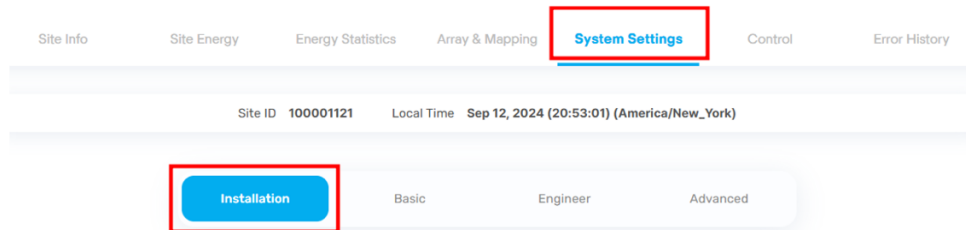
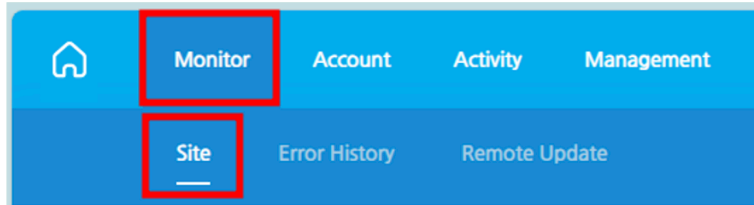

**Q12: Array mapping failed in the Q.OMMAND PRO app. How do I fix this?**

A: 1. Check whether the Q.OMMAND PRO app has been updated to the latest version.

2. If the problem persists, record the customer's mobile OS type and version and contact Qcells Customer Support for further guidance. Qcells Customer Support can be reached by calling 888-249-7750 or emailing [na.support@qcells.com](mailto:na.support@qcells.com).

3. Array mapping can be done manually at the end of the commissioning process.

**Q13: Why wasn't my setting applied in the Q.OMMAND PRO app?**

A: 1. Check whether the system is online. If the product is offline, make sure that the Q.HOME COMBINER (combiner box) has power, the Wi-Fi dongle is properly inserted, and the dongle is connected to Wi-Fi.

2. Check whether the Q.OMMAND PRO app has been updated to the latest released version. This can be checked in application settings, or via the relevant app store.

**Q14: What does the “Changes” function do in the Q.OMMAND PRO app?**

A: The 'Changes' function allows users to select existing sites and modify or replace the Q.HOME COMBINER, microinverters, and modules.

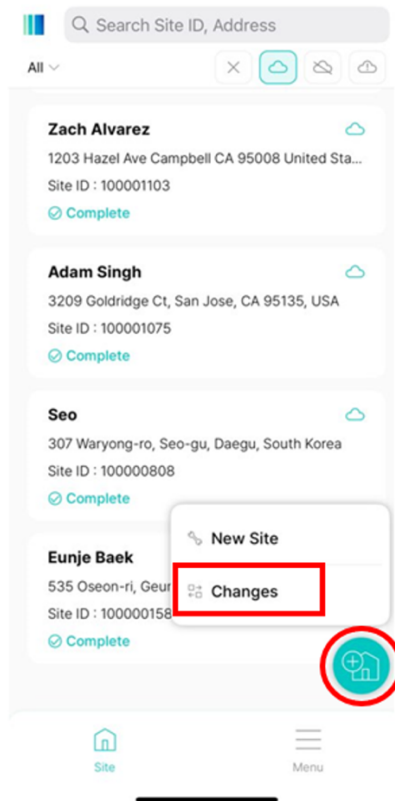

**Q15: Why are the consumption numbers negative?**

















A: Check the direction of the Consumption CTs. The arrows on the CTs should point towards the load, and away from the grid. If reversing the direction of the CTs does not fix the issue, then check the CT phases. Ensure that CT monitoring L1 (matching the Gateway’s L1 terminal) is plugged into the CT1 port, and the CT monitoring L2 (matching the Gateway’s L2 terminal) is plugged into the CT2 port.

Consumption numbers can also be negative if there is another generation source like another solar system, or a generator.

**Q.HOME COMBINER (Combiner Box)**

**Q16: What do the LED lights in the Q.HOME COMBINER (combiner box) mean?**

A: There are three LED indicator lights. See below.

Interface/Indication		Meaning		
		User Interface Button: - Turns on display, starts & stops AC module scanning		
LED Indications  	All LEDs	RED  Blinking	Powering up	
		GREEN  Blinking	Power up complete, ready to operate	
		RED  Solid	At least one paired AC module is not reporting	
		GREEN  Solid	All paired AC modules are reporting	
		GREEN  Blinking	AC module scan is in progress	
		OFF	No paired AC modules are communicating (low light or night time)	
		RED  Solid	At least one paired AC module is not producing power	
		GREEN  Solid	All paired AC modules are producing power	
		GREEN  Blinking	AC module firmware update in progress	
		OFF	No paired AC modules are communicating (low light or night time)	
		RED  Solid	No connection to Qcells server	
		GREEN  Solid	Connection established with Qcells server	
	OFF	No network connection		

**Q17: What do the numbers on the display screen mean?**

A: During normal operation, the display switches back and forth between the total number of AC modules connected and the total power output of the system. If the system has an error, this screen will show the error code.

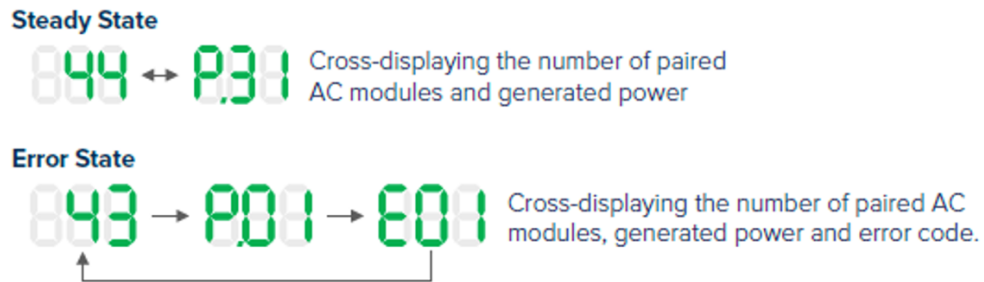

**Q18: Why isn't the display in my combiner box showing anything?**

A: Press the User Interface Button to turn on the screen. It will turn off automatically after one hour. If the User Interface Button does not work, the combiner box does not have power.

**Q19: What types of wires are needed to physically connect to the combiner box?**

A: Branch Breakers: Each 20A branch breaker must be fed by #8, #10, or #12 AWG wire

Main Lug to grid connection:

20A 10-8 AWG

40A 6-4 AWG

60A 4-2 AWG

80A 3-2/0 AWG

Consumption CT (5.2 meters long) is included, must be fed by 20-18 AWG twisted pair wire

**Q20: What does the sticker next to the PV2 input mean?**

A: The input phasing on the PV2 input is reversed from the other PV inputs. For the PV2 input only, L2 (red wire) is on top and L1 (black wire) is on bottom. See the yellow box on the picture below and note the phasing difference.

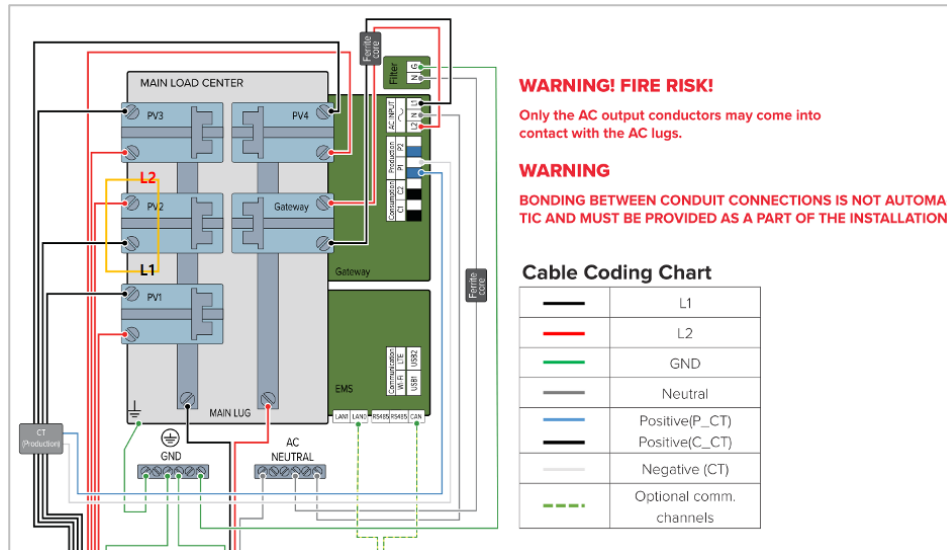

**Q21: Where do I plug in the Wi-Fi dongle?**

A: Use the USB port located below LED Screen marked “Wi-Fi” (Right side of the combiner box). The USB port marked “LTE” is only for the Cellular Modem accessory, the Wi-Fi dongle will not function in this USB port.

Please refer to location 8 below.

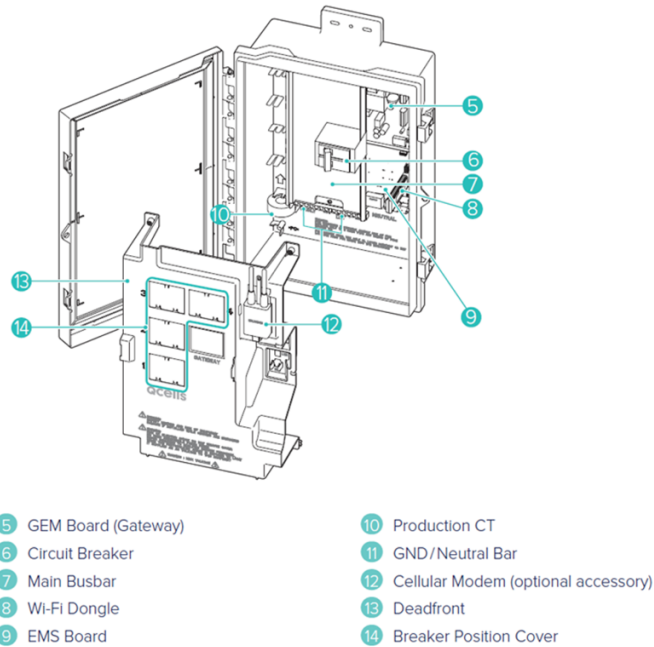

**Q22: The combiner box has no power. How do I fix this?**

A: 1. Check if the combiner box is receiving PV power. First make sure each PV breaker is in the on position, then use a multimeter to check that there is voltage on each PV breaker.

2. Check if the combiner box is receiving grid power. Use a multimeter to check if the grid voltage (240V AC) can be measured at the combiner’s main lugs. If no voltage is detected, check AC disconnect and PV breaker on main service panel.

3. Check if the main lugs in the combiner box are correctly wired. L1 (black) lands on the left lug, and L2 (red) lands on the right lug.

4. If the combiner box is receiving both PV and grid power and is still shut down, contact Qcells Customer Support by calling 888-249-7750 or emailing [na.support@qcells.com](mailto:na.support@qcells.com).

**Q23: The Q.OMMAND PRO app failed to connect to the combiner box.**

A: 1. Scan the QR code again. Sometimes multiple attempts are required to connect to the combiner box.

2. Check whether the Q.OMMAND PRO App is updated to the latest version.

3. Ensure the correct QR code is being scanned, as there are two QR codes on the inside of the front cover. Cover the QR code for the install manual and scan again to ensure your device is scanning the correct QR code (these QR codes are adjacent).

4. Keep the device physically near the combiner box during commissioning.

5. Make sure the Wi-Fi Dongle is connected to the Combiner Box, it is required for wireless pairing.

**Q24: Where do I find the QR code to connect the combiner box to Wi-Fi?**

A: The QR code is located inside the combiner box's front cover.

**Q25: Why is the QR Code scanner showing a URL instead of the combine box serial number?**

A: There are two QR codes on the inside of the front cover. Please ensure the correct QR code is being scanned. The left QR code contains the combiner box serial number (SN). The right code contains a URL for the installation manual. To avoid errors, try physically covering the installation manual QR code to ensure the commissioning device scans the correct QR code.

**Q26: I input the serial number incorrectly when connecting to the combiner box. How can I correct this?**

A: Use the back button in the Q.OMMAND PRO app to return to the previous screen and re-enter the serial number. You can also scan the QR code on the inside cover of the combiner instead.

**Q27: Why won't the system connect to Wi-Fi if the Wi-Fi Dongle is connected?**

A: 1. Be sure that the Internet Connection Settings shows Wi-Fi selected as the connection type.

2. Also consider the distance between the homeowner's Wi-Fi network and the combiner box or obstructions that may affect signal strength.

3. Make sure the Wi-Fi dongle is inserted into the correct USB port in the combiner box.

**Q28: Why did the system stop communicating after a firmware update?**

A: The system commonly reboots after updating firmware. The combiner box may need to be reconnected to Wi-Fi after the reboot.

**Q29: Do I need the homeowner's password to reconnect the system to Wi-Fi after the system rebooted from a firmware update?**

A: The Wi-Fi dongle stores the network credentials, so once the Wi-Fi dongle has been connected to the homeowner's network, re-entering the Wi-Fi password is not required.

## Panels and Microinverters

**Q30: Some AC modules are not detected during the PLC scan. How do I fix this?**

A: 1. Check that all PV string breakers in the combiner box are closed.

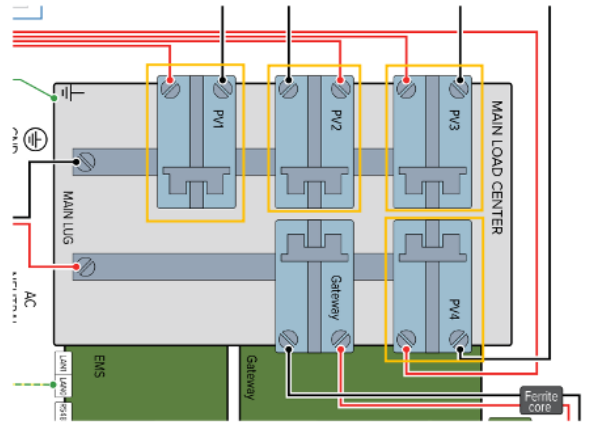

2. Check that the number of AC modules entered in the Q.OMMAND PRO app and PLC Scan menu. These numbers should match the number of installed AC modules.

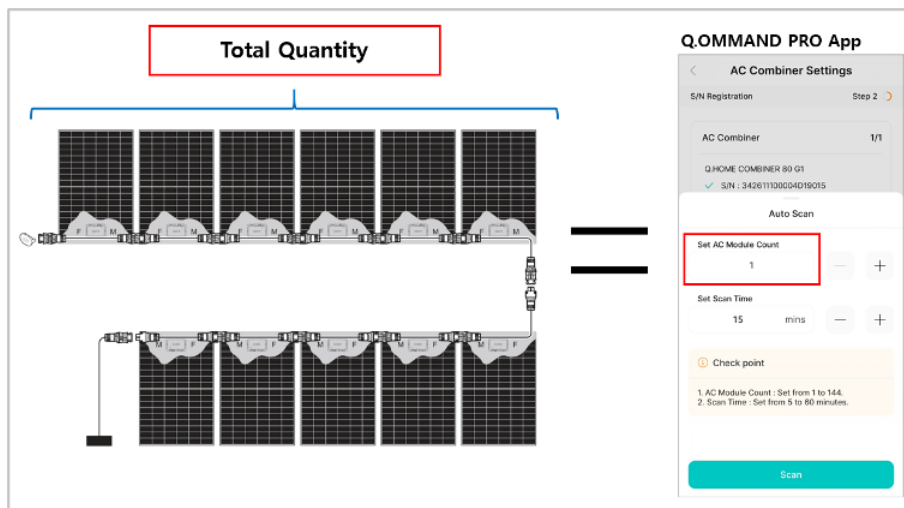

3. Check the serial numbers of the scanned AC modules in the Q.OMMAND PRO app, find the modules that were not scanned, and make sure the cables on these panels are fully secured.

4. Disconnect the DC/AC (PV) connector, wait for 10 seconds, and then reconnect it.

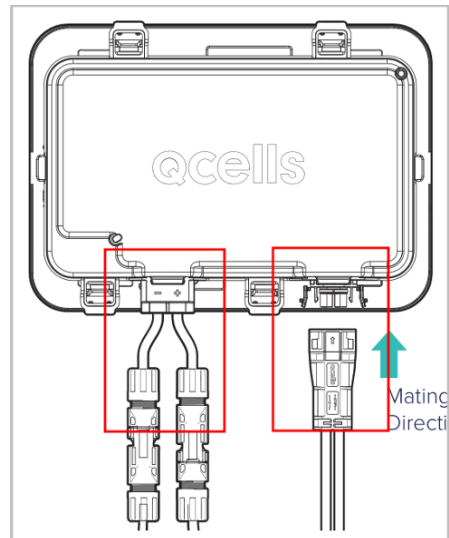

5. After checking the cable connection status, try the PLC scan again.

**Q31: Too many AC modules were detected during the PLC scan. How do I fix this?**

A: Check the number of AC modules entered in the Q.OMMAND PRO app and PLC Scan menu. These numbers should match the number of installed AC modules.

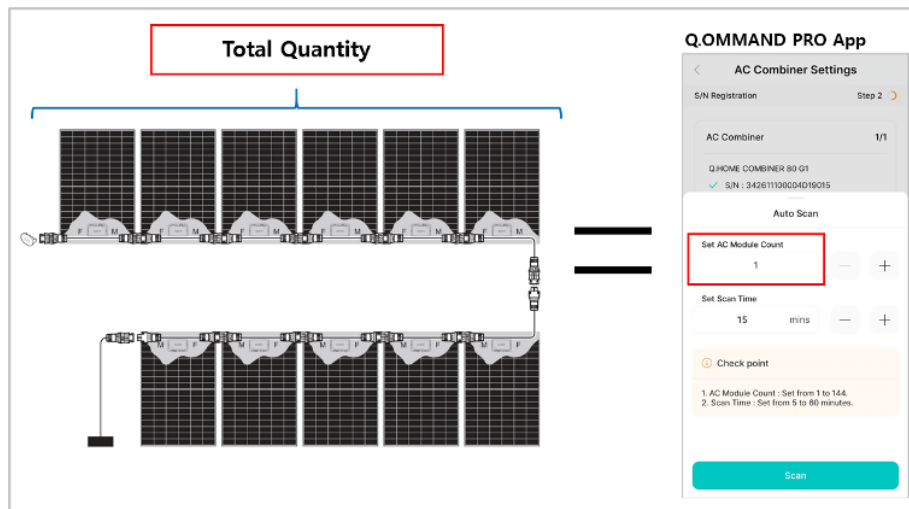

**Q32: Why did my PLC scan fail?**

A: Check if the PLC scan timed out in the Q.OMMAND PRO app, and try scanning for a longer time by increasing the PLC scanning time in the app. The maximum time setting is 60 minutes.

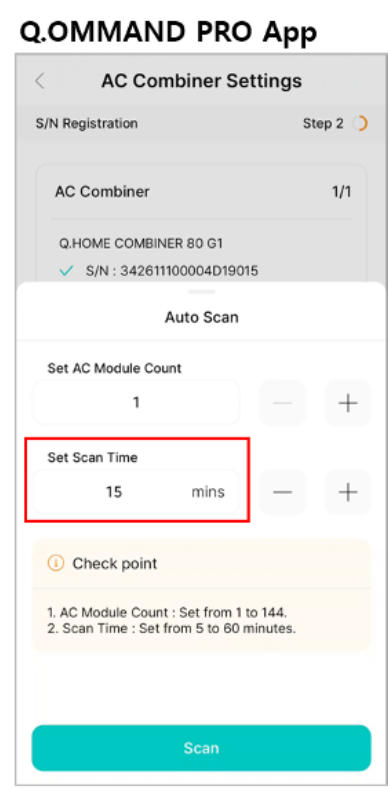

**Q33: How does the PLC scan work? What factors can affect the PLC scan?**

A: Power-line communication, or PLC, allows devices to communicate over a conductor used for AC power transmission by way of a set frequency that's transmitted between these devices. External factors can affect the clarity of the signal and disrupt communications. Distance can also play a role in reliable communication. If AutoScan is unable to find all devices, manual entry is also possible.

**Q34: Why does each microinverter need to be scanned twice?**

A: The initial scanning of the microinverters pairs each microinverter with the combiner box. Once the commissioning process is complete, an array map must be created in

Q.OMMAND PRO. This mapping process requires scanning each microinverter to build an accurate map showing the location of each AC module.

**Q35: The serial numbers won't scan when making the array map.**

A: Ensure there is ample lighting on the sticker sheet. If scanning the sticker sheet doesn't work, the array map can also be created manually.

**Q36: How do I contact Qcells Customer Support?**

A: Qcells Customer Support can be reached by calling 888-249-7750, or by emailing [na.support@qcells.com](mailto:na.support@qcells.com).